

PMC-550J

Low-voltage Motor Control and Protection Relay

User Manual

Version: V1.1

May 6, 2026

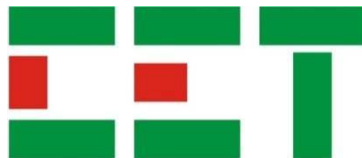



DANGER AND WARNING

This equipment can only be installed by professionals and the manufacturer will bear no responsibility for the failures caused by operations which do not conform to this manual.

Electric shock, Fire or Explosion

- Installation and maintenance of the meter should only be performed by the qualified persons.
- Before any operation on the equipment, voltage input and power supply should be isolated and the secondary windings of all the current transformers should be short-circuited.
- Please ensure that all incoming AC power and other power sources are turned OFF before any operation on the meter.
- All the mechanical components, doors and lids should be put in place before supplying power to the equipment.
- Please input rated voltage to the running equipment.

Failure to abide by the abovementioned instructions may result in severe injury.

This manual may not be reproduced in whole or in part by any means without the express written permission from CET Inc.

The information contained in this manual is believed to be accurate at the time of publication; however, CET Inc. assumes no responsibility for any errors which may appear here and reserves the right to make changes without notice. Please consult CET Inc. or your local representative for the latest product specifications.

Table of Contents

Chapter 1 Introduction	1
1.1 Overview	1
1.2 Features	1
1.3 PMC-550J's Application in Motor Control and Protection Circuit	4
1.4 Getting more information	4
Chapter 2 Installations	5
2.1 Appearance	5
2.1.1 Main Unit	5
2.1.2 Accessories	6
2.2 Dimensions	7
2.2.1 Unit Dimensions	7
2.2.2 Terminal Dimensions	7
2.2.3 PMC-MTA Dimensions	7
2.2.4 Optional PMC-MIR Dimensions	8
2.2.5 Optional PMC-MIN Dimensions	10
2.3 Mounting	10
2.4 Power Supply Wiring	10
2.5 Chassis Ground Wiring	10
2.6 PMC-MTA Wiring	10
2.7 Optional Residual Current Input Wiring	11
2.8 Optional Neutral Current Input Wiring	12
2.9 Digital Input Wiring	12
2.10 Digital Output Wiring	12
2.11 Optional Analog Output Wiring	12
2.12 Communications Wiring	12
2.12.1 RS-485 Wiring	12
2.12.2 Optional PROFIBUS Wiring	13
2.12.3 USB-C Wiring	13
2.13 Starter Wiring	13
2.13.1 Direct-On-Line Start	14
2.13.2 Reduce-voltage Start	15
2.13.3 Forward-reverse Start	18
2.13.4 Two-speed Start	19
2.13.5 VFD Start	20
2.13.6 Large Motor Start	21
Chapter 3 Front Panel	22
3.1 Front Panel LED Indicators	22
3.2 Front Panel Navigation Buttons	22
3.3 Front Panel Control Buttons	23
3.4 Front Panel Display	23
3.4.1 Default Display	23
3.4.2 Main Menu	23
3.4.3 Metering	24
3.4.4 DI/DO	25
3.4.5 View Parameters	25
3.4.6 Logs	25
3.4.7 Setup	27
3.4.8 Statistics	35
3.4.9 Maint.	35
3.4.10 Info	37
Chapter 4 Applications	38
4.1 Digital Inputs	38
4.1.1 Parameters	38
4.1.2 DI Mode	38
4.2 Digital/Relay Outputs	39
4.2.1 DO Mode	39
4.2.2 Parameters	40
4.2.3 Non-Fail-Safe Mode	40

4.3 Optional Analog Output.....	40
4.4 Protection Overview	41
4.4.1 Motor States	41
4.4.2 Protection and Motor State.....	42
4.4.3 Protection Reset Mode.....	42
4.4.4 Mechanical Protection and Control.....	42
4.4.5 Electrical Fault Protection and Control.....	54
4.5 Local/Remote Control Mode	60
4.6 Undervoltage Restart.....	61
4.7 Starter Function	62
4.8 Communication Test.....	63
4.9 Control Logic Test	63
4.10 Programmable Logic	63
4.11 Metering and Monitoring	63
4.11.1 Metering	63
4.11.2 Statistic	64
4.11.3 SOE (Sequence of Events).....	65
4.11.4 Protection Log.....	65
4.11.5 Start Report	65
4.11.6 Stop Report.....	65
4.12 Self-check.....	66
4.13 Data Recorder	66
4.14 Wiring Diagnosis	66
4.15 WFR (Waveform Recorder).....	66
4.16 Enhanced Power Supply	67
Chapter 5 Modbus Map.....	68
5.1 Real-time Relay Data.....	68
5.2 Statistic	70
5.3 Real-time Metering Data	70
5.4 Energy Measurement	71
5.5 Harmonics Measurement	71
5.6 Individual Harmonics	71
5.7 Device Setting	72
5.7.1 System Setting	72
5.7.2 Protection and Control Setting.....	73
5.7.3 DI Setting	76
5.7.4 DO Setting.....	77
5.7.5 Programmable Logic	77
5.8 Data Logging	78
5.8.1 Protection Log.....	78
5.8.2 SOE Log	79
5.8.3 Start Report	79
5.8.4 Stop Report.....	80
5.9 Data Recorder	81
5.10 Control Operations	81
5.11 Time Registers.....	82
5.12 Device Information	83
Appendix A – SOE and Protection Log Classifications.....	84
Appendix B – Technical Specification	89
Appendix C – Accuracy Specification	90
Appendix D – Relay Elements Specifications	91
Appendix E – Standard Compliance.....	93
Contact us.....	94

Chapter 1 Introduction

This manual explains how to use the PMC-550J Low-voltage Motor Protection Relay. Throughout the manual, the term “relay” generally refers to all models.

This chapter provides an overview of the PMC-550J and summarizes many of its key features.

1.1 Overview

The PMC-550J Low-voltage Motor Protection Relay provides a combination of protection, metering, monitoring, control and communications in a compact size with a backlit LCD screen. The PMC-550J offers extensive I/O with 8xDIs, 5xDOs, 1xZero-Sequence Current Input, 1xRS-485 port as well as optional 1xAnalog Output, 1xResidual Current Input and 1xPROFIBUS-DP communication port. Connection to external Current Transducer (MTA) provides phase current measurement suitable for applications up to 800A. With an enhanced power supply option, the PMC-550J can maintain normal operation under power interruption for 30 seconds.

1.2 Features

Functional Diagram

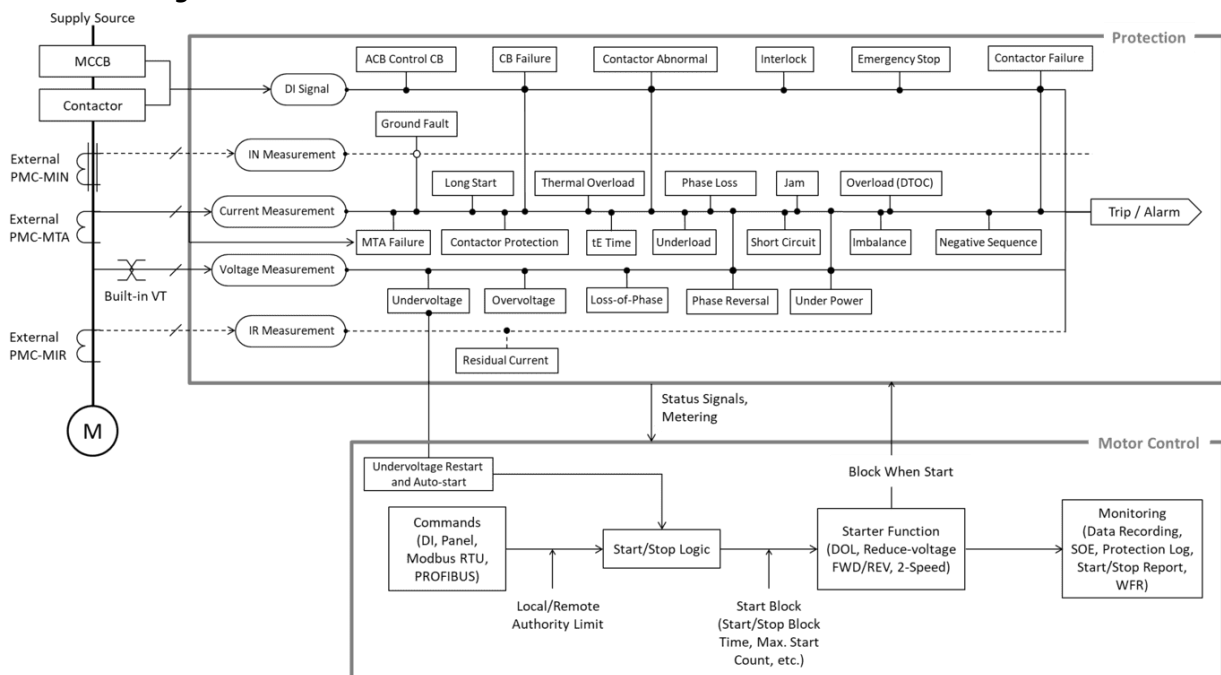

Figure 1-1 PMC-550J's Functional Diagram

Motor Start

The PMC-550J offers the generic motor control functions, such as Direct-on-line, Forward-Reverse and Two-Speed Start control. It also offers advanced motor starting schemes to reduce high starting and surge currents to prevent troublesome voltage dips on the mains supply and transient torque effects in mechanical systems. Use the PMC-550J to facilitate the motor ON/OFF sequence control.

Applications

- Direct-on-line Start
- Reduce-voltage Start (including Star-Delta Start, Auto-transformer Start and Resistance Start)
- Forward-Reverse Start
- Two-Speed Start
- VFD Start and Large Motor Start

Motor Control

The PMC-550J is a microprocessor-based device, which allows user to program and configure its operation through its Front Panel to determine the actions to be done in accordance with the situations.

- **Under-voltage Restart.** This control mode is designed to restart a motor accordingly after a voltage dip. It may be either a quick restart, delay restart or stop, depending on the characteristic of the voltage dip.
- **Auto-start.** This function is to determine the actions to be done after a machine stoppage due to a long undervoltage period. It may be either a “restart” or “recover to the state before stoppage”.
- **Local/Remote Control.** The PMC-550J allows the motor control to be done through local panel or remote control.

Motor Protection

Electric motor has Electrical and Mechanical operation limits. Exceeding these limits may cause power loss, mechanical vibration, stoppage, thermal damage and eventually destroy the motor. These incidents may lead to raw material loss, equipment damage, non-quality production and production loss. These may also have direct or indirect impact on human safety. The PMC-550J is not just designed to overcome these incidents and prevent their impacts from causing damage to equipment, it is also designed to enhance the motor performance, hence to improve the entire system reliability and productivity.

Protection Schemes

Electrical Fault Protection – Short Circuit, Ground Fault, Residual Current, Loss-of-Potential (LOP), Negative Sequence, MTA Failure, Overvoltage, Undervoltage, Imbalance, Phase Reversal.

Mechanical Protection – Jam, Long Start, Thermal Overload, Overload, Under Power, Interlock, tE Time, Contactor Failure, Block When Start.

Metering and Monitoring

Fundamental Metering

- Line Voltage (UAB, UBC, UCA) and Current (IA, IB, IC) per phase and average
- Phase Angle
- IA/Ie ratio (%), IB/Ie ratio (%), IC/Ie ratio (%) and Iavg/Ie ratio (%)
- I1 (positive sequence), I2 (negative sequence) and Current Unbalance (%)
- 3I0 (calculated neutral current) or optional IN (measured neutral current)
- Total kW, kvar, kVA and PF
- Cooling Time (s) and Heat Capacity (%)
- Optional Ir (Residual Current)
- System Frequency

RMS Metering

- Line Voltage (Uab, Ubc, Uca) and Current (Ia, Ib, Ic) per phase and average
- Phase Angle
- Ia/Ie ratio (%), Ib/Ie ratio (%), Ic/Ie ratio (%)
- Total kW, kvar, kVA and PF
- Total kWh Import/Export and Total kvarh Import/Export

Harmonic Metering

- U and I THD, TOHD and TEHD
- U and I Individual Harmonics from 2nd to 31st
- Latest motor operating statistics including Trip Current, Trip Times, Start Current, Start Time, Start Counter, Running Time, Stop Time, etc.

Motor Monitoring and Statistics

- 64 time-stamped logs recording DI/DO status changes, Diagnostic logs and Maintenance events
- 64 time-stamped protection logs recording protection active events with characteristic values
- Start Report stores the latest 64 motor start logs recording Start Control Source, Maximum Start Current, Minimum Start Voltage, Start Time, Time Stamp and Start Result
- Stop Report stores the latest 64 motor stop logs recording Stop Control Source, IA, IB, IC and Timestamp
- Waveform Recorder triggered by motor start or protection operated, stores max. 16 logs recording of UAB, UBC, UCA, IA, IB, IC and IN

Data Recorder

- 10,000 entries
- Simultaneous recording of 3-phase ULL, Current as well as Total kW
- Recording Interval from 1 to 600 seconds
- Support FIFO or Stop-When-Full mode

Commission Test

- Communication Test by synchronizing the sample data to the workstation
- Control Logic Test for the relay's DI, DO and Protection Logic without interruption to the running motor

Programmable Logic

- Function Block Diagram (FBD) programming language compliant with IEC 61131-3
- Create Logic control equation with a drag-and-drop text editor via PMC-Designer

Inputs & Outputs

Digital Input

- Standard 8 or optional 6 channels, volts free dry contact, 24VDC Internal Excitation
- Status Input or Control Input

Digital Output

- Standard 5 channels (one Form B and Four Form A)
- Control and Status Indication

Analog Output (Optional)

- 4 – 20 mA programmable analog output to display the proportional DC signal on an external analog meter or DCS system
- Selectable analog quantity such as 3-phase Current, Total kW, Ir and IN

Communication

- 1xOptically isolated RS-485 port with Baudrate from 1.2 to 19.2 kbps
- 1xType C USB Port supporting Modbus RTU protocol
- Optional 1xPROFIBUS DP Interface supporting PROFIBUS DP protocol

System Integration

- The PMC-550J is supported by CET's PMC-EasyConfig. In addition, it can be easily integrated into other 3rd party Automation or SCADA system because of its support of multiple communication ports and the Modbus RTU, PROFIBUS DP protocol.

1.3 PMC-550J's Application in Motor Control and Protection Circuit

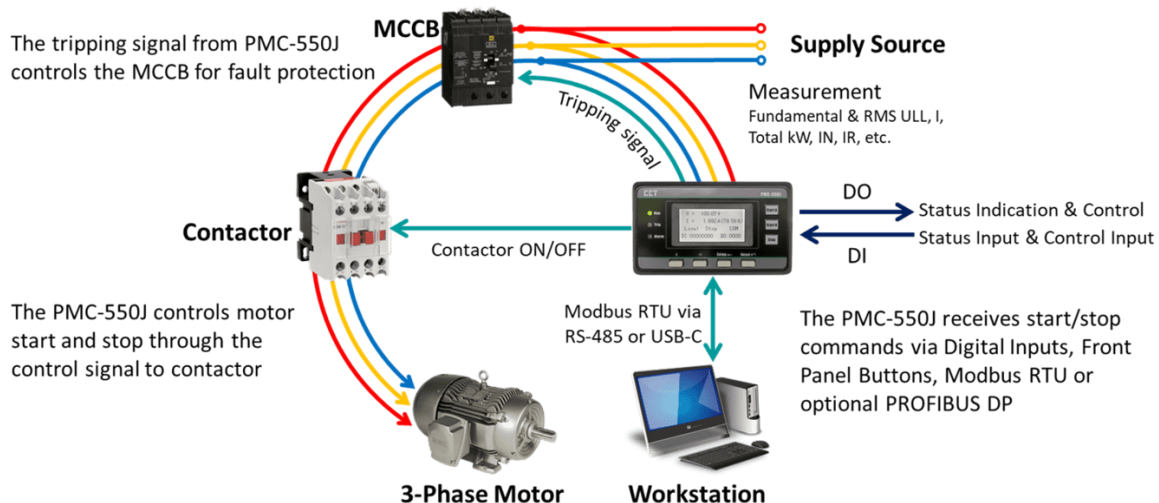

Figure 1-2 PMC-550J's Application in Motor Control and Protection Circuit

1.4 Getting more information

Additional information is available from CET via the following sources:

- Visit www.cet-global.com
- Contact your local representative

Contact CET directly via email at support@cet-global.com

Chapter 2 Installations

2.1 Appearance

2.1.1 Main Unit



Figure 2-1 Front Panel

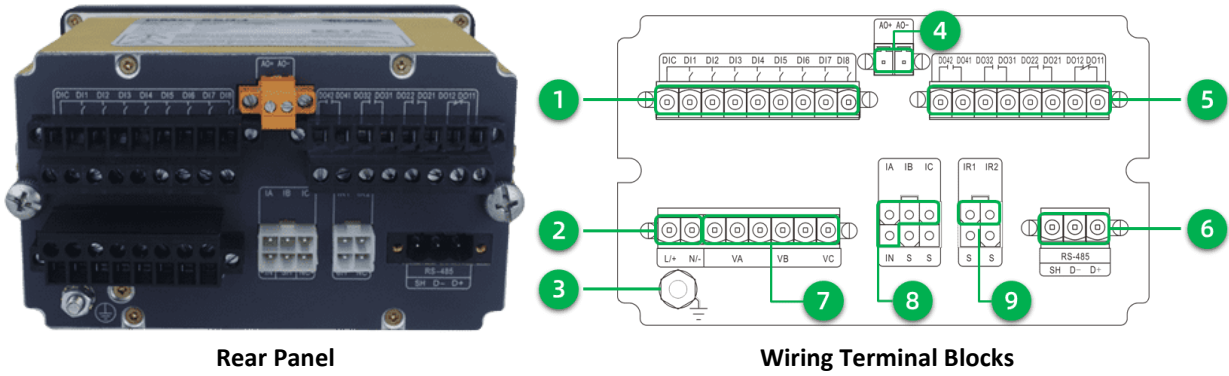

Rear Panel

Wiring Terminal Blocks

Figure 2-2 Rear Panel and Terminals (8xDI + 4xDO + 1xAO + 1xIR)

No.	Terminal Labels	Descriptions
1	DIC, DI1 to DI8	8x Digital Input
2	L/+, N/-	Power Supply
3	⊕	Chassis Ground
4	AO+, AO-	1x Analog Output
5	DO11, DO12, DO21, DO22, DO31, DO32, DO41, DO42	4x Digital Output
6	D+, D-, SH	1x RS-485
7	VA, VB, VC	3x Voltage Input
8	IA, IB, IC, IN	3x Current Input (connect to PMC-MTA)
9	IR1, IR2	1x Residual Current Input (connect to PMC-MIR)

Table 2-1 Terminal Descriptions (8xDI + 4xDO + 1xAO + 1xIR)

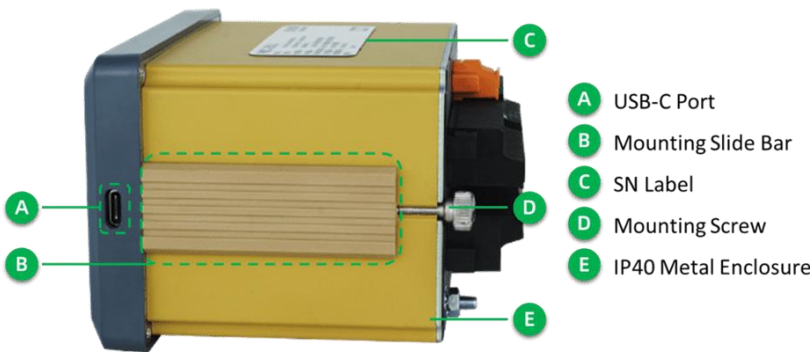

Side Panel

Figure 2-3 Side Panel and SN Label

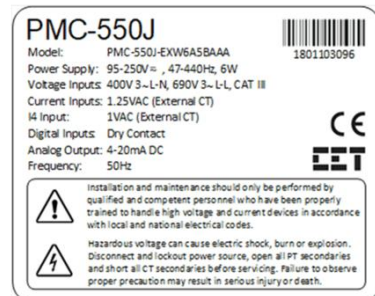

SN Label

2.1.2 Accessories

2.1.2.1 PMC-MTA Motor Current Transducers



No.	Models	No.	Models
1	PMC-MTA-1A	5	PMC-MTA-100A
2	PMC-MTA-400A-T	6	PMC-MTA-300A
3	PMC-MTA-5A	7	PMC-MTA-800A-T
4	PMC-MTA-25A		

Figure 2-4 PMC-MTA Motor Current Transducers Appearance

2.1.2.2 Optional PMC-MIR Residual Current Transducers



No.	Models	No.	Models
1	PMC-MIR-35	4	PMC-MIR-50
2	PMC-MIR-120	5	PMC-MIR-265*103
3	PMC-MIR-75		

Figure 2-5 Optional PMC-MIR Residual Current Transducers Appearance

2.1.2.3 Optional PMC-MIN Zero Sequence Current Transducers

PMC-MIN-1A or PMC-MIN-5A



Figure 2-6 Optional PMC-MIN Neutral Current Transducer

2.2 Dimensions

2.2.1 Unit Dimensions

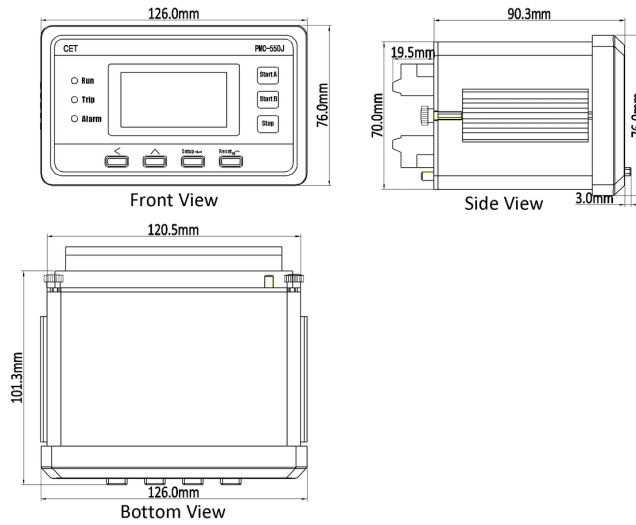

Figure 2-7 Unit Dimensions

2.2.2 Terminal Dimensions

No.	Terminals	Terminal Dimensions	Wire Size	Max. Torque
1	AO	□ 1.6mm x 2.5mm	0.2-1.2mm ² (16-24AWG)	2.17 in.lb/0.25 N.m/2.5 kgf.cm/M2
2	Voltage Input	□ 2.6mm x 2.0mm	0.5 - 3.5 mm ² (12-22AWG)	3.47 in.lb/0.9 N.m/4 kgf.cm/M2.5
3	Power Supply			
4	RS-485			
5	DI			
6	DO			

Table 2-2 Terminal Dimensions

2.2.3 PMC-MTA Dimensions

2.2.3.1 PMC-MTA-1A / PMC-MTA-5A

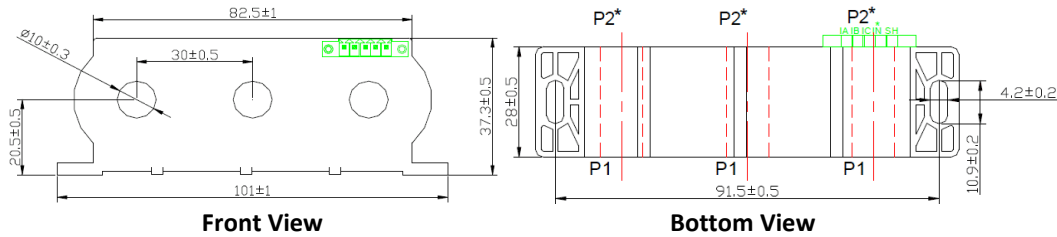

Figure 2-8 PMC-MTA-1A / PMC-MTA-5A Dimensions

2.2.3.2 PMC-MTA-25A

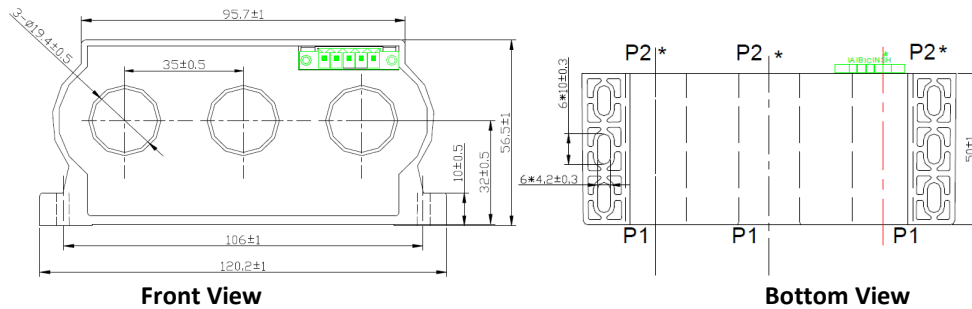

Figure 2-9 PMC-MTA-25A Dimensions

2.2.3.3 PMC-MTA-100A / PMC-MTA-300A

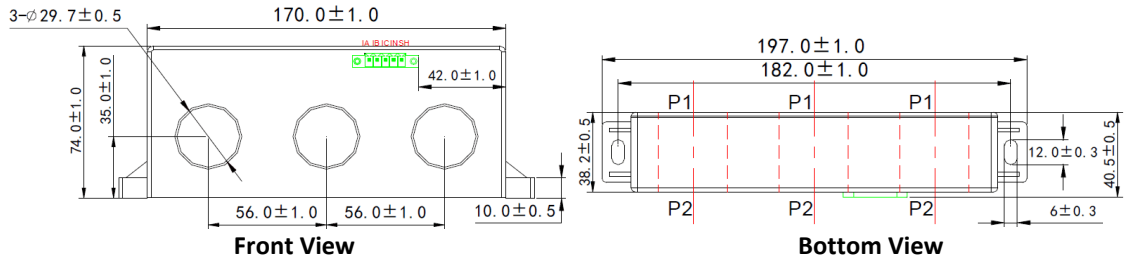

Figure 2-10 PMC-MTA-100A / PMC-MTA-300A Dimensions

2.2.3.4 PMC-MTA-400A-T

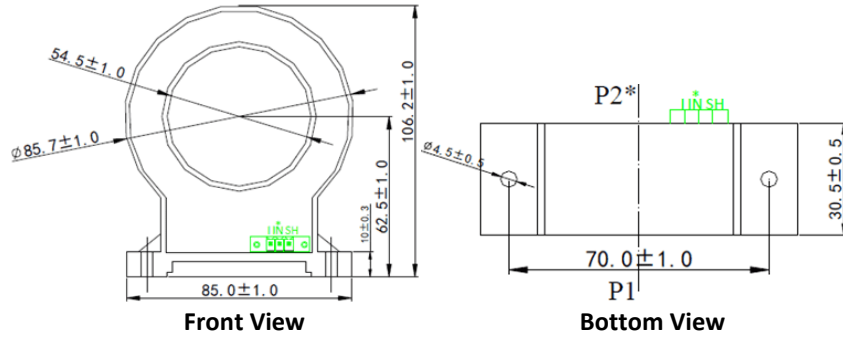

Figure 2-11 PMC-MTA-400A-T Dimensions

2.2.3.5 PMC-MTA-800A-T

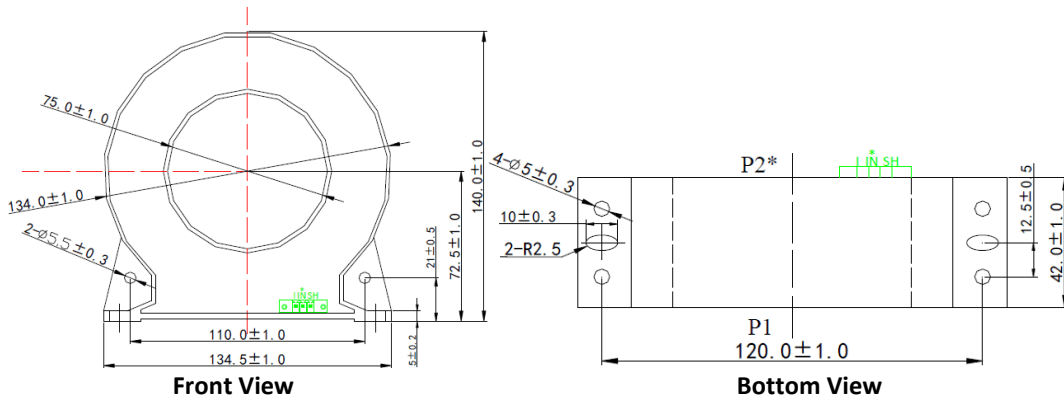

Figure 2-12 PMC-MTA-800A-T Dimensions

2.2.4 Optional PMC-MIR Dimensions

2.2.4.1 PMC-MIR-35

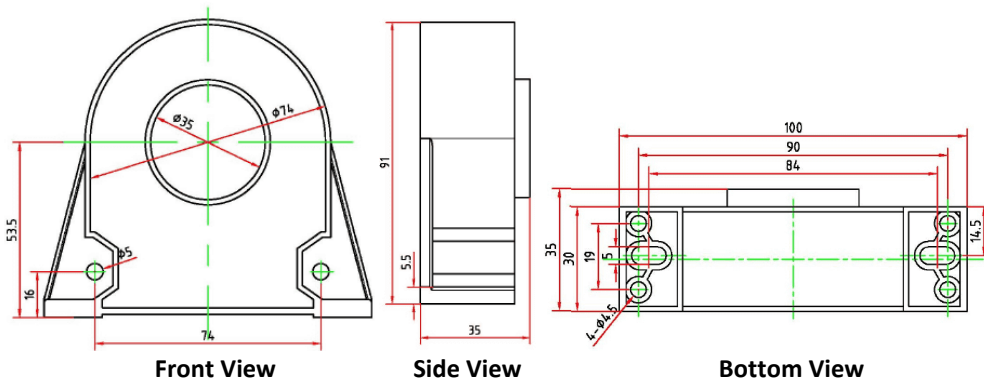

Figure 2-13 PMC-MIR-35 Dimensions

2.2.4.2 PMC-MIR-50

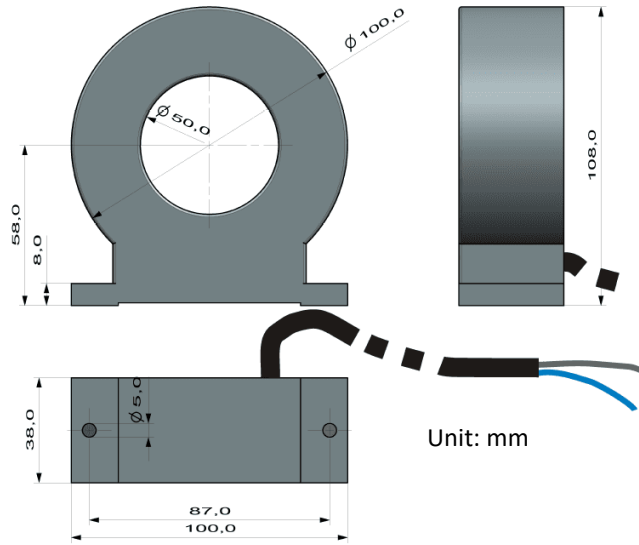

Figure 2-14 PMC-MIR-50 Dimensions

2.2.4.3 PMC-MIR-75

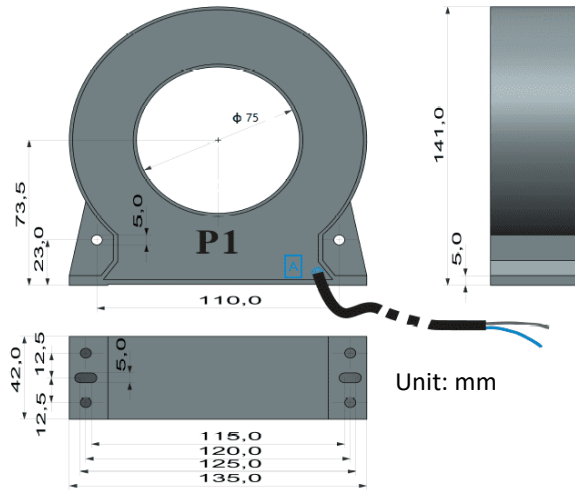

Figure 2-15 PMC-MIR-75 Dimensions

2.2.4.4 PMC-MIR-120

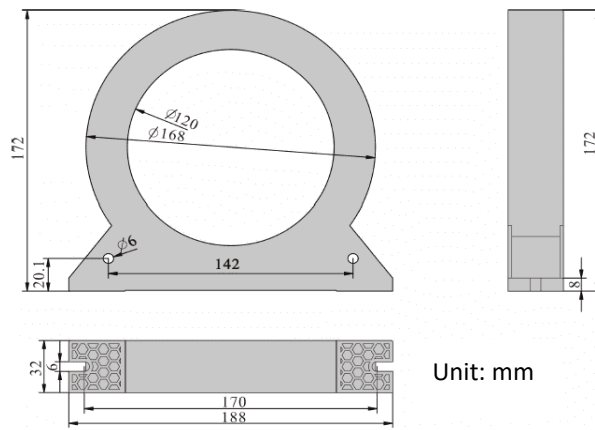

Figure 2-16 PMC-MIR-120 Dimensions

2.2.5 Optional PMC-MIN Dimensions

PMC-MIN-1A or PMC-MIN-5A

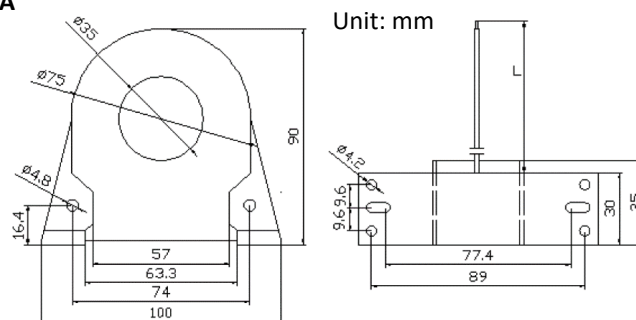

Figure 2-17 Optional PMC-MIN Dimensions

2.3 Mounting

The relay should be installed in a dry environment with no dust and kept away from heat, radiation and electrical noise sources.

Installation steps:

- Remove the mounting slide bars from the relay.
- Fit the relay through a 121mm x 71mm cutout as shown in Figure 2-18.
- Re-install the mounting slide bars and tighten the screws against the panel to secure the relay.

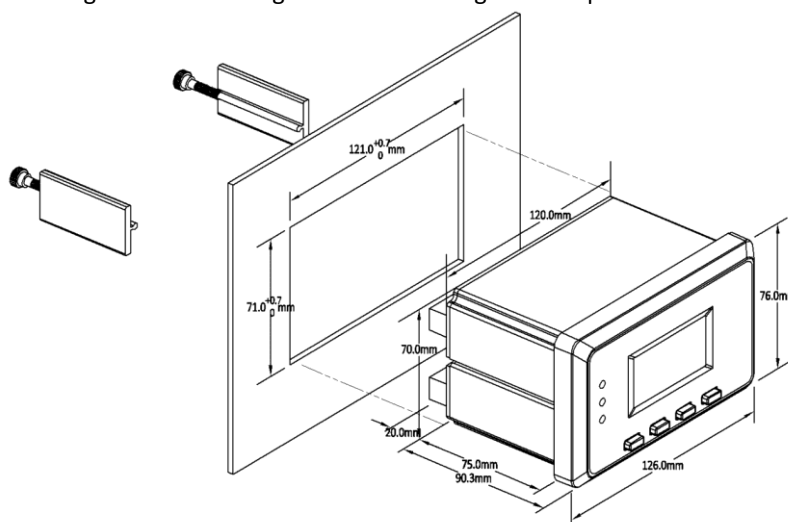

Figure 2-18 Panel Cutout Installations

2.4 Power Supply Wiring

The L/+, N/- terminals on the relay must connect to 95 - 250VAC/DC power source.

For AC supply, connect the live wire to the L/+ terminal and the neutral wire to the N/- terminal.

For DC supply, connect the positive wire to the L/+ terminal and the negative wire to the N/- terminal.

2.5 Chassis Ground Wiring

The ground terminal of the relay must connect to the chassis or cabinet ground (always marked with PE) with yellow/green striped wire to ensure personnel safety.

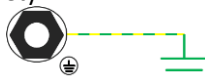

Figure 2-19 Chassis Ground Wiring

2.6 PMC-MTA Wiring

For PMC-MTA-1A/5A/25A/100A/300A, these MTAs come with a pluggable connector at the end of the output which consists of 5 wires with colorful insulated cover, **IA** (yellow), **IB** (green), **IC** (red), **IN** (black) and **SH** (black). Insert the pluggable connector securely into the Current Input terminals on the PMC-550J. Put the motor wires through the aperture in the MTA. Take care of the correct phase sequence and feed through direction indicated on the MTA.

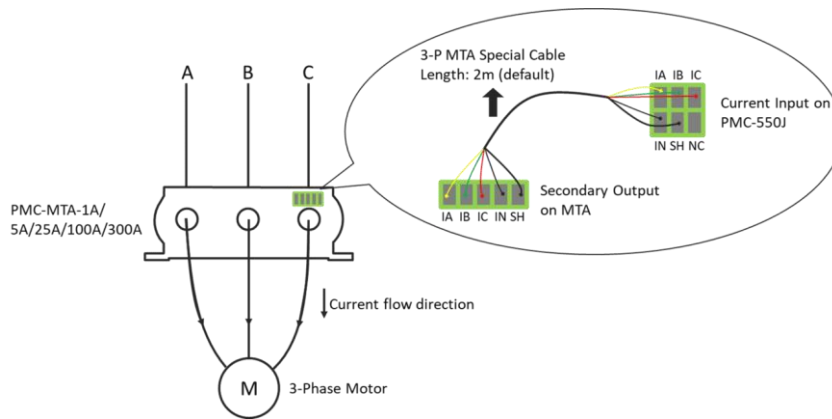

Figure 2-20 PMC-MTA-1A/5A/25A/100A/300A Connections

For PMC-MTA-400A-T and PMC-MTA-800A-T, one relay should be connected to 3 pieces of identical MTA which transforms the motor current IA, IB and IC, separately. Connect the MTA's output wires to the relay via the attached pluggable connector. The red wire from I terminal of the 3 MTAs should be connected to the IA, IB, and IC of the relay's current input independently. The black wires from the 3 MTA's IN should be connected to the relay's IN. And the black SH wires should be connected to the relay's SH. Put the motor wires through the 3 MTAs separately. Take care of the correct phase sequence and feed through direction indicated on the MTA.

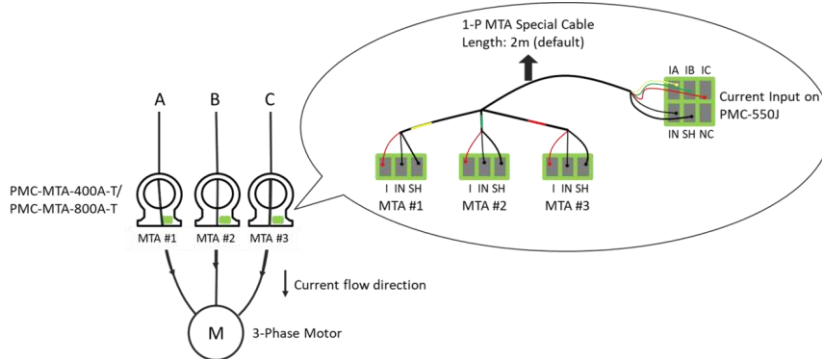

Figure 2-21 PMC-MTA-400A-T / PMC-MTA-800A-T Connections

Notes

1. The MTAs should be installed in the upstream of the VFD, star-delta or 2-speed circuit.
2. The rated input of Current Input terminals is 1.25V voltage. Please **DO NOT** input a current or a higher voltage to the relay.
3. **DO NOT** ground the IN terminal on the relay.

2.7 Optional Residual Current Input Wiring

The following figure illustrates the Residual Current connections on the PMC-550J. Put the three phase and neutral (when used) wires of motor circuit through the center of the PMC-MIR residual current transducer. Connect the MIR's output to the relay's IR1, IR2 and SH terminals with the pluggable connector.

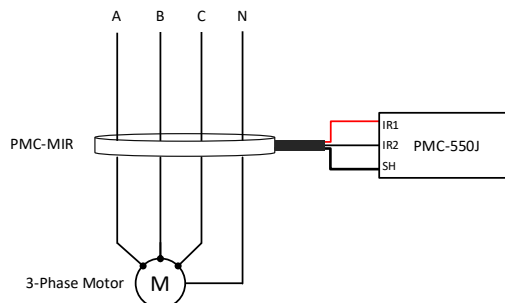

Figure 2-22 Optional Residual Current Input Connection

2.8 Optional Neutral Current Input Wiring

Connect the **I41, I42** terminals to the output of PMC-MIN neutral current transducer. Put the secondary output (current signal) of the neutral current transformer through the PMC-MIN transducer. Please note that the rated input of **I41, I42** terminals is 1VAC voltage. Please **DO NOT** input a current or a higher voltage signal to the relay.

2.9 Digital Input Wiring

The relay supplies 24VDC wetting voltage for each input and a module, PMC-KI will be needed to convert the sampling voltage if the user desires to use 110VDC/AC or 220VDC/AC voltage. In this condition, the **DI Excitation** shall be configured as **External** and the minimum debounce (also called hysteresis sometimes) time shall be 600ms. The following figure illustrates the connection for PMC-KI and DIs.

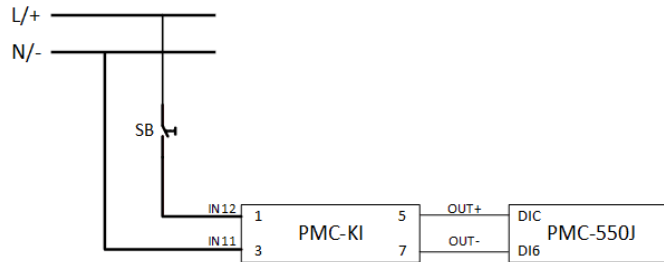

Figure 2-23 Digital Input Connection with PMC-KI Converter

2.10 Digital Output Wiring

The relay comes standard with a Form B (DO1), Four Form A (DO2 to DO5) output contacts. The DO2 supports either NC or NO contacts based on the model option selected. DO1 to DO4 are rated for continuous carry current of 8A. DO5 is rated for continuous carry current of 5A (Refer to **Appendix B – Technical Specification**).

2.11 Optional Analog Output Wiring

The relay offers an optional Analog Output for operating a remote panel meter or as an input to the distributed control system (DCS). Please note that the relay supplies 24VDC voltage for the analog output.

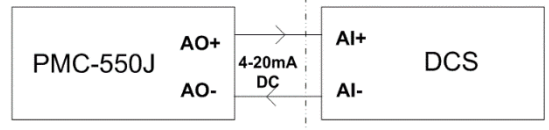

Figure 2-24 Optional Analog Output Wiring

2.12 Communications Wiring

2.12.1 RS-485 Wiring

The following figure illustrates the RS-485 communication wiring on the PMC-550J.

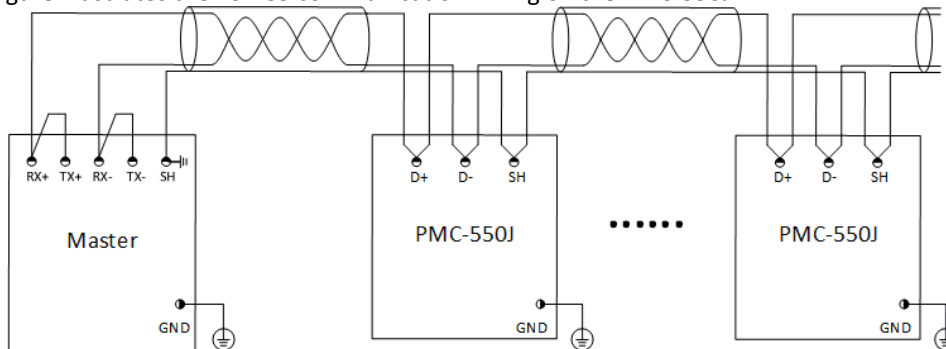

Figure 2-25 Wiring Diagram of RS-485 Communication

The PMC-550J provides one standard RS-485 port. Up to 32 devices can be connected on a RS-485 bus. The overall length of the RS-485 cable connecting all devices should not exceed 1200m.

If the master station does not have a RS-485 communication port, an Ethernet-to-RS-485 gateway or USB/RS-485 converter with optically isolated output and surge protection should be used.

2.12.2 Optional PROFIBUS Wiring

The PMC-550J is integrated in a Profibus DP network by using a DB9 interface. The following figure illustrates the DB9 interface pinout. Please install a Profibus card with driver on the PC to connect the PMC-550J via Profibus interface directly.

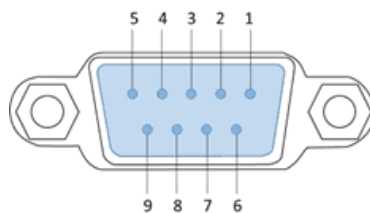

Figure 2-26 D-SUB9 Connector Pinout

The following table illustrates the functions assigned to the pinout of the D-SUB9 connector.

D-SUB 9 (pin)	Signal	Function
3	D (B) positive	Data receive and transmit (positive)
8	D (A) negative	Data receive and transmit (negative)
5	DGND	Reference potential for +5V and data
6	VP	+5V for terminating resistors (active termination)

Table 2-3 Pin Assignments for the DB9 Connector on PMC-550J

2.12.3 USB-C Wiring

The PMC-550J provides a USB-C interface supporting standard Modbus RTU communications. Please use the specialized USB-C/RS-232 wire to connect the master and the relay.

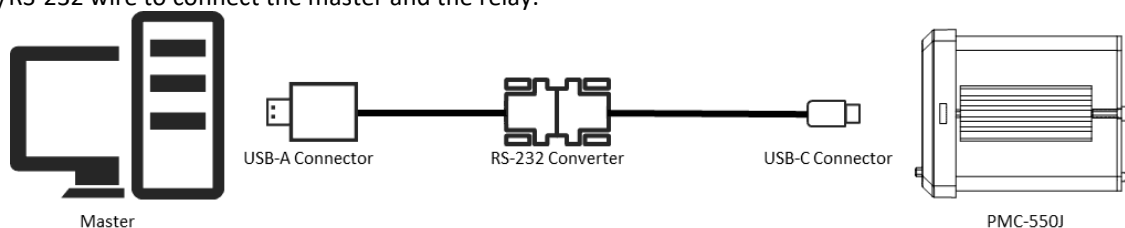

Figure 2-27 USB-C Wiring

2.13 Starter Wiring

The relay supports multiple motor starter modes. Please read this section carefully before installation and choose the correct starter mode. The following starter modes are supported:

- Direct-On-Line
- Reduce-voltage
- Forward-reverse
- Two-speed
- Variable Frequency Driver (VFD) Start
- Large Motor Start

2.13.1 Direct-On-Line Start

Use this mode to start/stop a motor in one direction rotation. The following diagram shows the wiring for DOL Operation. The main contactor is connected to DO1 and DO2 for the control function. An auxiliary contactor of KM is connected to DI7 for contactor status supervision. The motor can be started locally via DI2 and stopped via DI3.

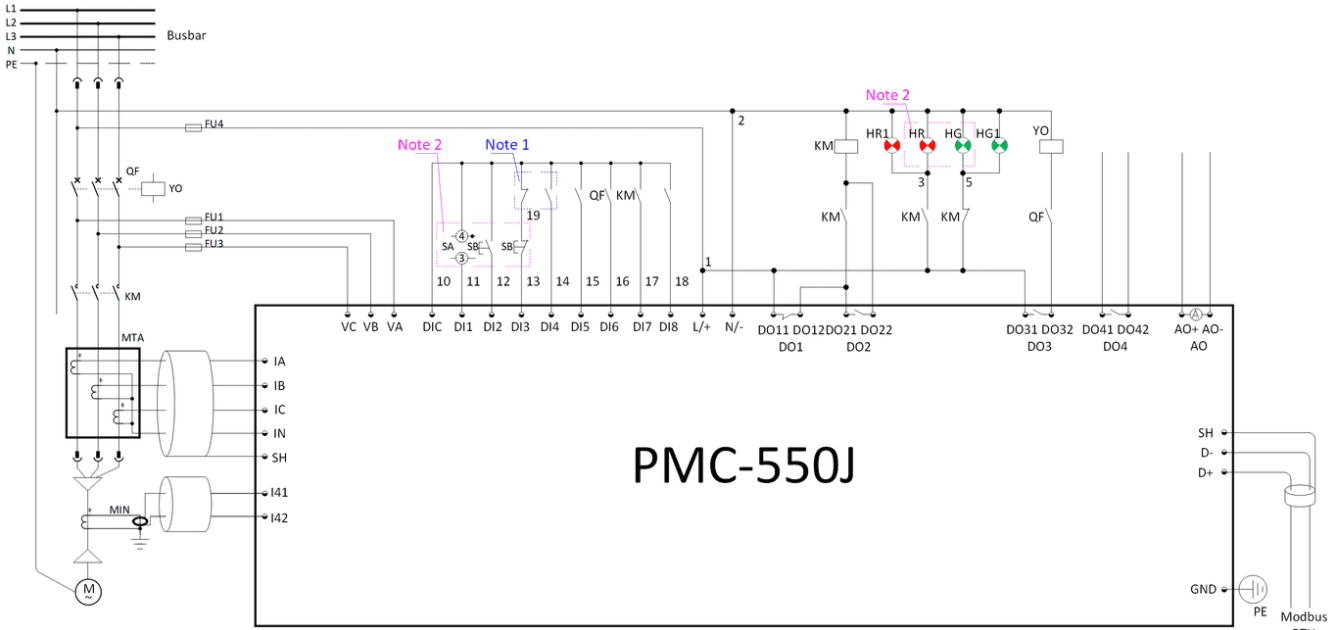

Notes:

1. The marked region are connected to the DCS or other operating system.
2. The marked region are connected to the motor control center drawer.

I/O Configurations (8DI + 4DO + 1AO)

DI1	DI2	DI3	DI4	DI5	DI6	DI7	DI8	DO1	DO2	DO3	DO4
Local/remote control switch	Local start	Stop	Remote start	Common state input	QF state input	KMA State	Common state input	Trip contactor	Start A	Trip ACB	Spare

Components Descriptions

KM	Contactor	YO	Shunt trip breaker
SB	Push button switch	MIN	PMC-MIN
SA	Selector switch	MTA	PMC-MTA
QF	Circuit breaker	HR, HR1*	Red indicators for motor start
FU1 - FU4	Fuse	HG, HG1*	Green indicators for motor stop

*The HR1 & HG1 are connected to the switchgear or power distribution center.

Figure 2-28 DOL Start Schematic Diagram

2.13.2 Reduce-voltage Start

Induction motors draw excessive current when started at full voltage, which will affect the whole power system. Thus, reduce-voltage start is applied to decrease the starting current. The relay supports the Reduce-voltage start methods including Star-Delta Start, Auto-transformer Start, Resistance Start.

Star-Delta Start

In Star-Delta start, a motor is connected in a wye connection throughout the starting period. Once the motor's running speed reaches its normal speed within the specified time delay, the motor begins to run in a delta connection.

The following diagram shows the wiring for Star-Delta operation. DO1 is connected to the main contactor (KMC) for control and protection functions. DO2 is used to control the star contactor (KMA) and DO3 is used to control the delta contactor (KMB). Two auxiliary contacts are connected to DI6 and DI7 for contactor status supervision. The motor can be locally started via DI2 and stopped via DI3.

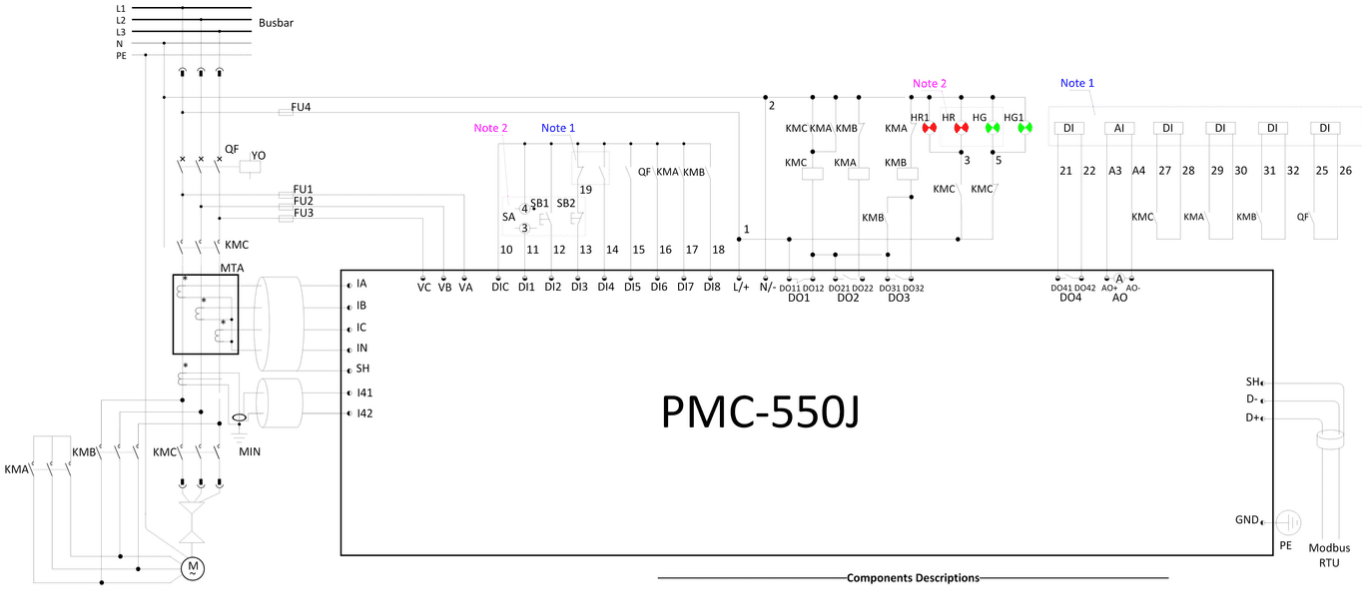

Notes:

1. The marked region are connected to the DCS or other operating system.
2. The marked region are connected to the motor control center drawer.

I/O Configurations (8DI + 4DO + 1AO)			
DI1	Local/remote control switch	DI5	Common state input
DI2	Local start	DI6	QF state input
DI3	Stop	DI7	KMA state
DI4	Remote start	DI8	KMB state
DO1	Trip contactor	DO2	Start A (reduce-voltage)
DO3	Start B (full-voltage)	DO4	Alarm

Components Descriptions			
KMA, KMB, KMC	Contactors	YO	Shunt trip breaker
SB	Push button switch	MIN	PMC-MIN
SA	Selector switch	MTA	PMC-MTA
QF	Circuit breaker	HR, HR1*	Red indicators for motor start
FU1 - FU4	Fuse	HG, HG1*	Green indicators for motor stop

*The HR1 & HG1 are connected to the switchgear or power distribution center.

Figure 2-29 Star-Delta Start Schematic Diagram

Auto-transformer Start

In Auto-transformer start, the motor is connected to a tapping of an autotransformer to obtain a suitable voltage throughout the start period. Once the motor's running speed reaches its normal speed within the specified time delay, the autotransformer will be isolated from the motor circuit and the motor begins to run at the full rated voltage.

The following diagram shows the Auto-transformer start control. DO1 is used for control and protection functions. DO3 is used to control the start circuit (KMA – transformer secondary, KMC – transformer primary). DO4 is used to control the running circuit (KMB). Three auxiliary contacts are connected to DI6 to DI8 for contactor status supervision. The motor can be locally started via DI2 and stopped via DI3.

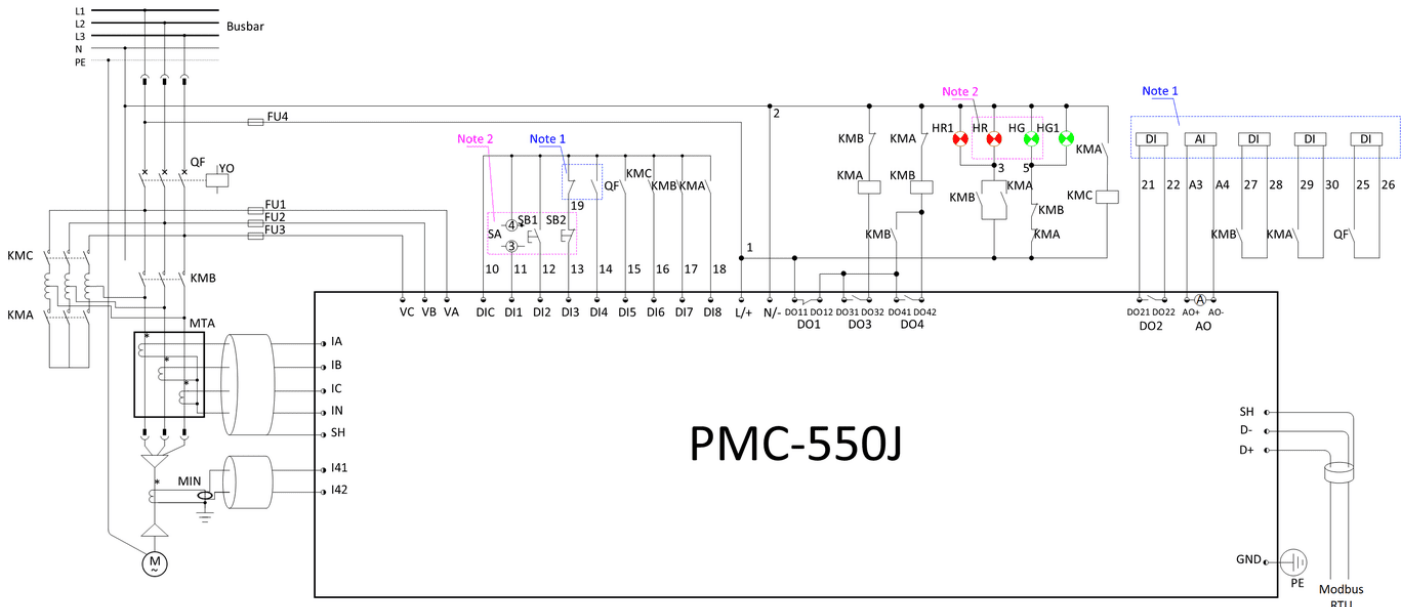

Notes:

1. The marked region are connected to the DCS or other operating system.
2. The marked region are connected to the motor control center drawer.

I/O Configurations (8DI + 4DO + 1AO)			
DI1	Local/remote control switch	DI5	QF state input
DI2	Local start	DI6	Common state input
DI3	Stop	DI7	KMB State
DI4	Remote start	DI8	KMA State
DO1	Trip contactor	DO3	Start A (reduce-voltage)
DO2	Alarm	DO4	Start B (full-voltage)

Components Descriptions

Symbol	Description	YO	Function
KMA, KMB, KMC	Contactor	YO	Shunt trip breaker
SB	Push button switch	MIN	PMC-MIN
SA	Selector switch	MTA	PMC-MTA
QF	Circuit breaker	HR, HR1*	Red indicators for motor start
FU1 - FU4	Fuse	HG, HG1*	Green indicators for motor stop

*The HR1 & HG1 are connected to the switchgear or power distribution center.

Figure 2-30 Auto-Transformer Operation Schematic Diagram

Resistance Start

In Resistance start, the motor is connected to a variable resistor in series to obtain a reduced voltage throughout the start period. Once the motor current reaches the predefined threshold after a specified time delay, the resistor will be disconnected from the motor circuit and the motor begins to run at a full rated voltage.

The following diagram shows the Resistance Start operation. DO1 is used for control and protection functions. DO3 is used to control the start circuit (KMA) and DO4 is used to control the running circuit (KMB). Two auxiliary contacts are connected to DI7 and DI8 for contactor status supervision. The motor can be started locally via DI2 and stopped via DI3.

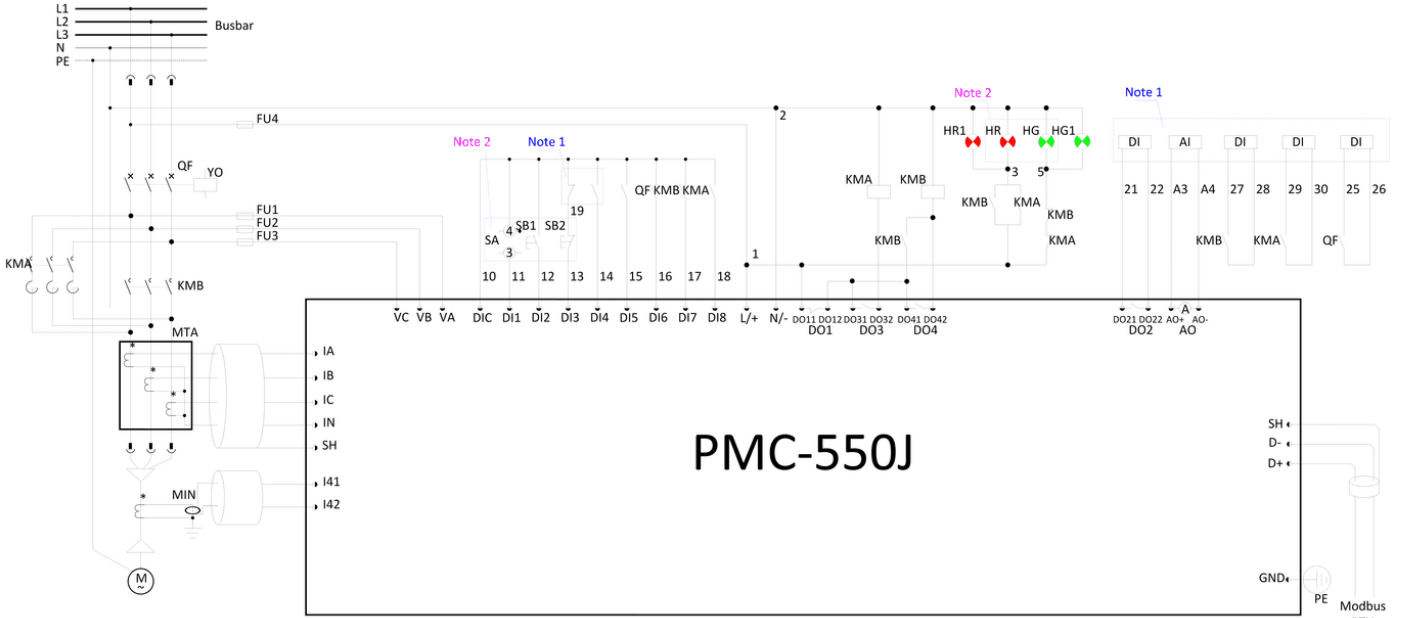

Notes:

1. The marked region are connected to the DCS or other operating system.
2. The marked region are connected to the motor control center drawer.

I/O Configurations (8DI + 4DO + 1AO)

DI1	Local/remote control switch	DI5	Common state input	DO1	Trip contactor
DI2	Local start	DI6	QF state input	DO2	Alarm
DI3	Stop	DI7	KMB State	DO3	Start A (reduce-voltage)
DI4	Remote start	DI8	KMA State	DO4	Start B (full-voltage)

Components Descriptions

KMA, KMB	Contactor	YO	Shunt trip breaker
SB	Push button switch	MIN	PMC-MIN
SA	Selector switch	MTA	PMC-MTA
QF	Circuit breaker	HR, HR1*	Red indicators for motor start
FU1 - FU4	Fuse	HG, HG1*	Green indicators for motor stop

*The HR1 & HG1 are connected to the switchgear or power distribution center.

Figure 2-31 Resistance Start Operation Schematic Diagram

2.13.3 Forward-reverse Start

Use this function to start/stop a motor in two directions of rotation, forward and backward or upward and downward. The following diagram illustrates the wiring for Forward-reverse operation. The DO1 is used for control and protection functions. DO2 is used to control forward contactor (KMA) and DO3 is used to control reverse contactor (KMB). Two auxiliary contacts are connected to DI7 and DI8 for contactor status supervision. The motor can be started locally via DI2/DI3 and stopped via DI4.

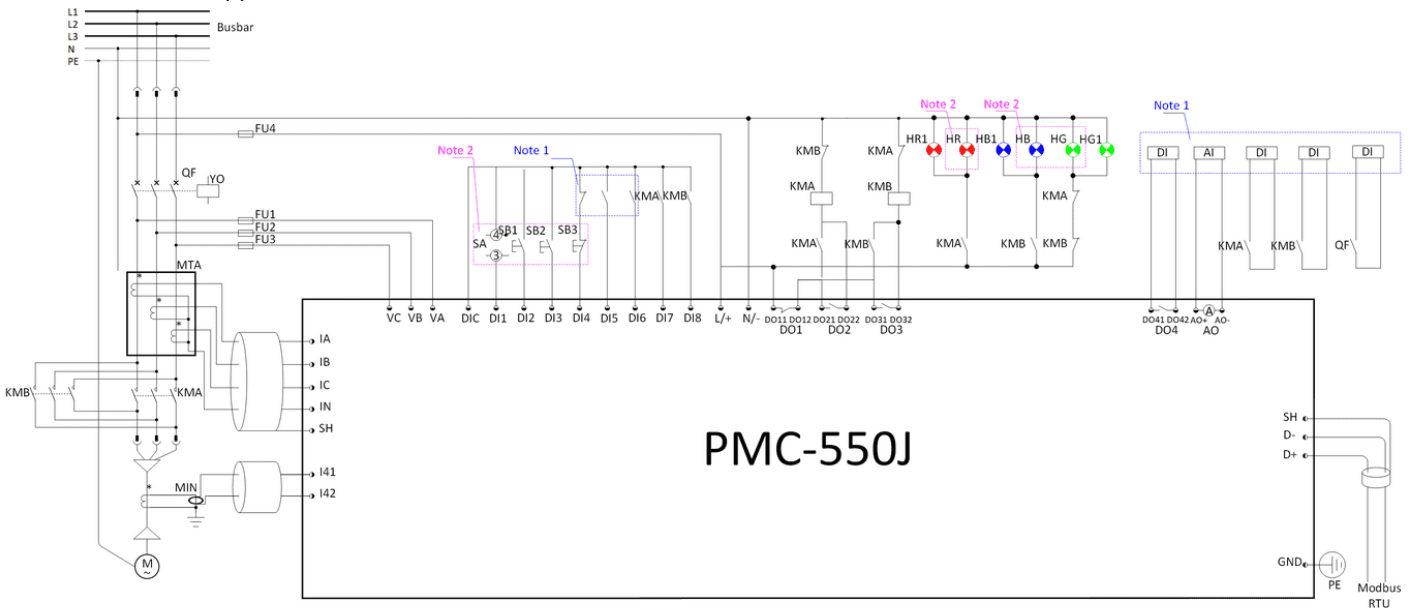

Notes:
 1. The marked region are connected to the DCS or other operating system.
 2. The marked region are connected to the motor control center drawer.

I/O Configurations (8DI + 4DO + 1AO)			
DI1	Local/remote control switch	DI5	Remote start A
DI2	Local start A	DI6	Remote start B
DI3	Local start B	DI7	KMA state
DI4	Stop	DI8	KMB state
DO1	Trip contactor	DO2	Start A (forward)
DO3	Start B (reverse)	DO4	Alarm

Components Descriptions			
KMA, KMB	Contactor	YO	Shunt trip breaker
SB	Push button switch	MIN	PMC-MIN
SA	Selector switch	MTA	PMC-MTA
QF	Circuit breaker	HR, HR1*	Red indicators for forward start
FU1 – FU4	Fuse	HG, HG1*	Green indicators for motor stop
HB, HB1*	Blue indicators for reverse start		

*The HR1, HG1 and HB1 are connected to the switchgear or power distribution center.

Figure 2-32 Forward-reverse Operation Schematic Diagram

Notes

- Opposite direction only possible after the motor is stopped and after the preset delay time has elapsed.
- If a motor is already in one direction rotation, the start command in the same direction will be ignored.
- Restart in the same direction without consideration of the preset delay time.

2.13.4 Two-speed Start

Use this function to start/stop a motor running at two speeds in one direction of rotation.

The following diagram illustrates the wiring for two-speed operation. The DO1 is used for control and protection functions. DO2 is used for control speed 1 contactor (KMA) and DO3 is used for control speed 2 contactor (KMB). Two auxiliary contacts are connected to DI7 and DI8 for contactor status supervision. The motor can be locally started via DI2/DI3 and stopped via DI4.

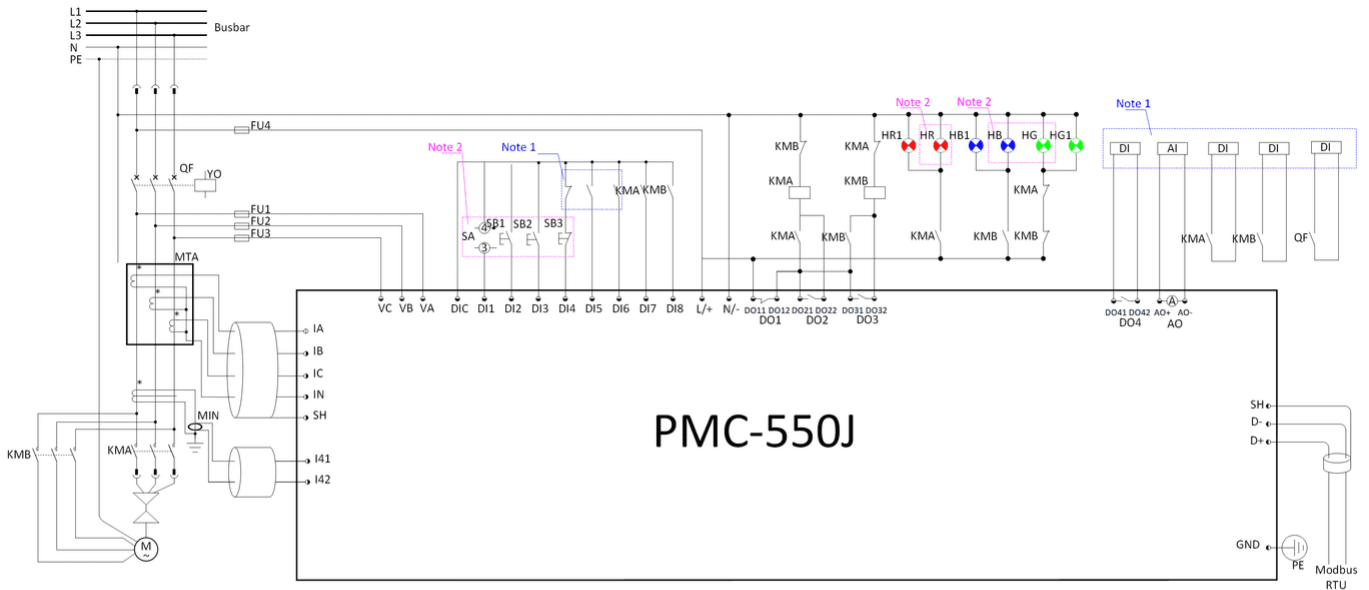

- Notes:**
 1. The marked region are connected to the DCS or other operating system.
 2. The marked region are connected to the motor control center drawer.

I/O Configurations (8DI + 4DO + 1AO)			
DI1	Local/remote control switch	DI5	Remote start A
DI2	Local start A	DI6	Remote start B
DI3	Local start B	DI7	KMA state
DI4	Stop	DI8	KMB state
DO1	Trip contactor		
DO2	Start A (speed 1)		
DO3	Start B (speed 2)		
DO4	Alarm		

Components Descriptions			
KMA, KMB	Contactor	YO	Shunt trip breaker
SB	Push button switch	MIN	PMC-MIN
SA	Selector switch	MTA	PMC-MTA
QF	Circuit breaker	HR, HR1*	Red indicators for speed 1
FU1 - FU4	Fuse	HG, HG1*	Green indicators for motor stop
HB, HB1*	Blue indicators for speed 2		

*The HR1, HG1 and HB1 are connected to the switchgear or power distribution center.

Figure 2-33 Two-speed Operation Schematic Diagram

Notes

- Alternative speed only possible after the motor is stopped and after the preset delay time has elapsed.
- If a motor is already running at a certain speed, the start command at the same speed will be ignored.
- Restart at the same speed without consideration of the preset delay time.

2.13.5 VFD Start

Use this function to start/stop a variable frequency drive (VFD) and its ventilation cooler sequentially. The cooler is desired to run before the VFD start process and stop until the VFD is turned off.

The following diagram illustrates the wiring for VFD start. The DO1 is used for control and protection functions. With DI2 (Local Start A) or DI4 (Remote Start A) operated, the relay closes DO4 to start the Cooler and after a specified time delay, the DO3 is also closed to start the VFD. In opposite, with DI3 (Stop) operated, the relay trips DO3 to stop the VFD first and after the time delay, the Cooler is stopped via DO2 configured as Trip Cooler (If DO Trip Cooler is not configured, the Cooler can be stopped via DO4 tripped). Two auxiliary contacts are connected to DI7 and DI8 for Cooler and VFD status supervision.

If the VFD is detected running while DI7 indicates the cooler is stopped, the **Contactors Abnormal Alarm** (See Section 4.4.5.10) will operate to stop the VFD and issue an alarm.

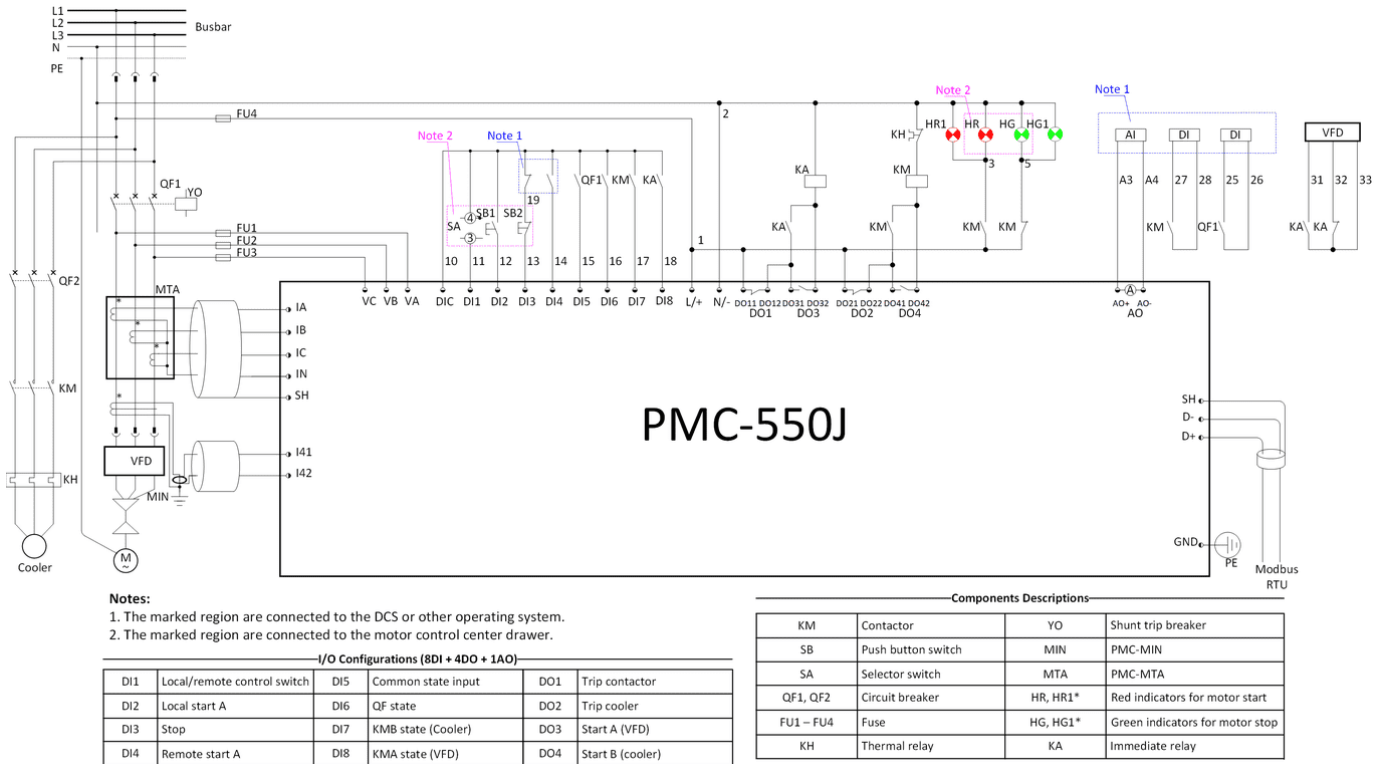

Figure 2-34 VFD Control Operation Schematic Diagram

2.13.6 Large Motor Start

Similar to VFD start control, use this function to start/stop the Large Motor and Small Motor sequentially.

The following diagram illustrates the wiring for Large Motor Start. The DO1 is used for control and protection functions. With DI2 (Local Start A) or DI4 (Remote Start A) operated, the relay closes DO4 to start the Small Motor and after a specified time delay, the DO3 is also closed to start the Large Motor. In opposite, with DI3 (Stop) operated, the relay trips DO3 to stop the Large Motor first and after the time delay, the Small Motor is stopped via DO2 configured as Trip S-Motor (If DO Trip S-Motor is not configured, the Small Motor can be stopped via DO4 tripped Directly). Two auxiliary contacts are connected to DI7 and DI8 for small and large motor status supervision.

If the large motor is detected to start (DI8 operated) before the small motor (DI7 operated), the **Contactorm Abnormal Alarm** (See Section 4.4.5.10) will activate to issue an alarm.

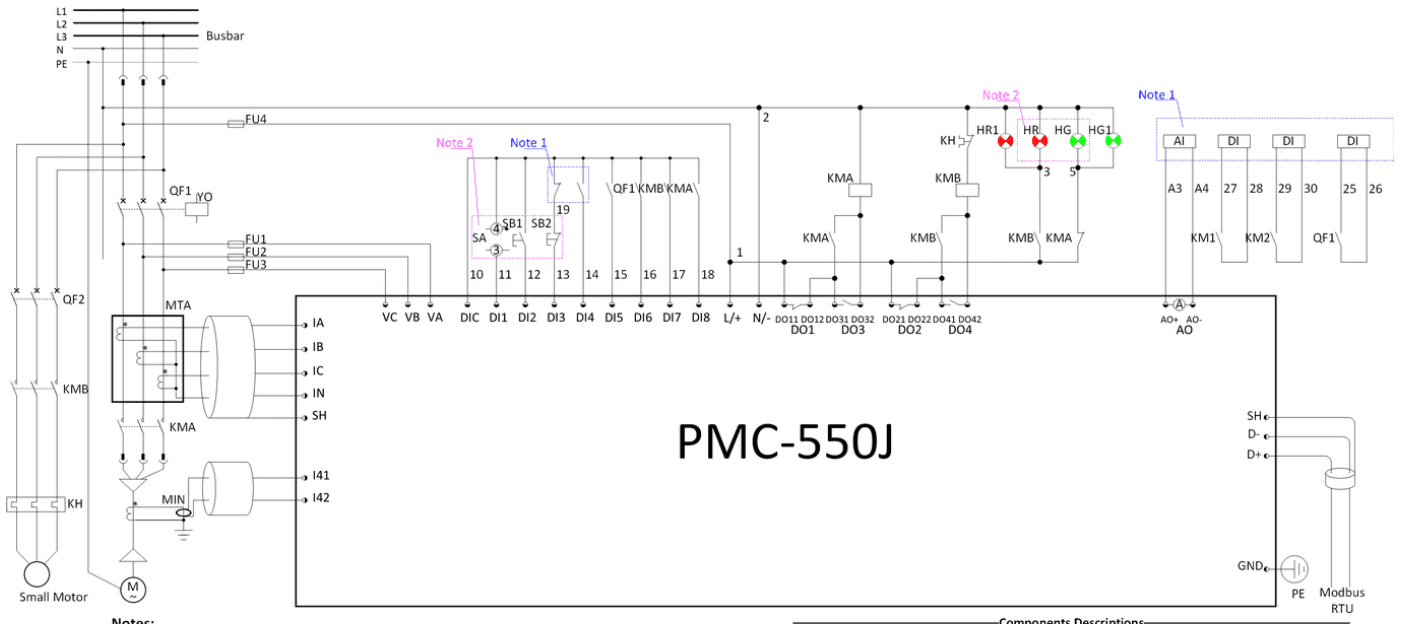

- Notes:**
 1. The marked region are connected to the DCS or other operating system.
 2. The marked region are connected to the motor control center drawer.

I/O Configurations (8DI + 4DO + 1AO)					
DI1	Local/remote control switch	DI5	Common state input	DO1	Trip contactor
DI2	Local start A	DI6	QF state	DO2	Trip small motor
DI3	Stop	DI7	KMB state (small motor)	DO3	Start A (large motor)
DI4	Remote start A	DI8	KMA state (large motor)	DO4	Start B (small motor)

Components Descriptions			
KMA, KMB	Contactor	YO	Shunt trip breaker
SB	Push button switch	MIN	PMC-MIN
SA	Selector switch	MTA	PMC-MTA
QF1, QF2	Circuit breaker	HR, HR1*	Red indicators for motor start
FU1 – FU4	Fuse	HG, HG1*	Green indicators for motor stop
KH	Thermal relay		

*The HR1 & HG1 are connected to the switchgear or power distribution center.

Figure 2-35 Large Motor Control Operation Schematic Diagram

Chapter 3 Front Panel

The PMC-550J has a large, easy to read Dot-Matrix LCD display with backlight and four navigation buttons for data display and meter configuration. There are three LED indicators for the relay and protection status, three control buttons for motor start/stop control.

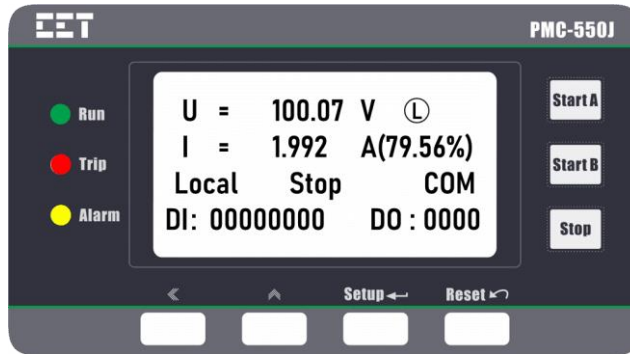

Figure 3-1 Front Panel

3.1 Front Panel LED Indicators

The meanings for the three indicators are described as below:

LED Indicators	Color	Status	Description
Run	Green	ON	Motor is running normally
		Blink once per 2s	Motor stops and device is running normally
		Blink once per 0.2s	Motor is starting
		OFF	Device is power off
Trip	Red	ON	Trip events occur
Alarm	Yellow	ON	Alarm events occur or Self-check failed

Table 3-1 Front Panel LED Indicators

The Trip/Alarm indicator will illuminate and latch in after target condition occur. At this point, the latched LED must be reset using the Reset button or the Reset command via DI or through Communications as long as the trip/alarm conditions have cleared.

3.2 Front Panel Navigation Buttons

The following table describes the functions for the navigation buttons <Left>, <Up>, <Setup <Left> and <Reset <Right>. Holding the <Reset <Right> button for 1s, the Trip/Alarm LED will turn off if the trip/alarm events conditions have cleared. While the trip/alarm condition remains, the Trip/Alarm LED stay lit.

Menu/Screen	Buttons		
	<Left> and <Up>	Setup <Left>	Reset <Right>
Default Screen	Toggles between the Default screen and Motor Start Block/Unblock screen	Enter the Main Menu	Ignored
Metering, DI/DO, View Para., Logs, Statistics, Info., Setup, Maint.	<ul style="list-style-type: none"> Before a menu/sub-menu is selected, pressing <Left> or <Up> shifts the cursor down/up in the Main menu/Sub-menu. Inside a particular sub-menu, pressing <Left> or <Up> moves forward/backward to display different parameters. 	Enter the selected menu/sub-menu.	Returns to the previous level menu or screen
If a parameter is selected in the sub-menu of Setup/Maint.,			
Setup, Maint.	<ul style="list-style-type: none"> For a numeric parameter, pressing <Up> increments a numeric value by one digit and pressing <Left> shifts the cursor to the left by one position. For an enumerated parameter, press <Up> to scroll through the selection list. 	<ul style="list-style-type: none"> Enter the selected parameter modification screen. Save the modification. Start the comm. test or control logic test. 	<ul style="list-style-type: none"> Exit the parameter setup screen without saving the modifications. Exit the comm. test of control logic test.

Table 3-2 Overview for Front Panel Navigation Buttons

3.3 Front Panel Control Buttons

The following table describes the functions for Start A, Start B and Stop button under different starter mode.

Control Functions	Buttons		
	Start A	Start B	Stop
Direct-On-Line	Start	-- (Not used)	Stop
Reduce-voltage	Reduce-voltage start	Full-voltage running	
Forward-reverse	Forward	Reverse	
2-speed	Speed 1	Speed 2	
VFD start	Start VFD	-- (Not used)	
L-Motor start	Start Large Motor	-- (Not used)	

Table 3-3 Overview for Front Panel Control Buttons

The user can make use of the Front Panel control buttons to start/stop the motor based on the **Control Key** setting (Under **Setup** -> **1 System** menu on the Front Panel). If the **Control Key** is set to **Disable**, the control buttons are not operational. **Control Key** set to **Emergency** means the Front Panel button control is always valid regardless of the **DI Local/Remote control switch** setting. And under other circumstances, the **Control Key** setting has to be consistent with the **DI Local/Remote control switch** to make the control buttons functional. If none of DI is configured as **Local/Remote control switch**, the **Control Key** has to be set to **Local** so that the Front Panel control can make sense.

3.4 Front Panel Display

3.4.1 Default Display

The PMC-550J has a Default Display that shows the metering of Voltage U (UAB), Current I (IA), Percent of I (IA) / Ie, motor control mode (Local or Remote), motor state (Stop, Start, Running, Forward, Reverse, Speed 1, Speed 2), RS-485 communication state (COM blinking means communication activity), DI state (1 means close, 0 means open, 00000000 stands for DI1 to DI8 open) and DO state (1 means operated, 0 means released, 0000 stands for DO1 to DO4 released). If the programmable logic is exported to the relay, the symbol Ⓛ will display on the default screen.

Pressing the ⏪ or ⏩ button will enter the Motor Start Block/Unblock screen that indicates motor start unblock or block condition with block reason (such as self-check failed, protection trip, etc.) and remaining block time.

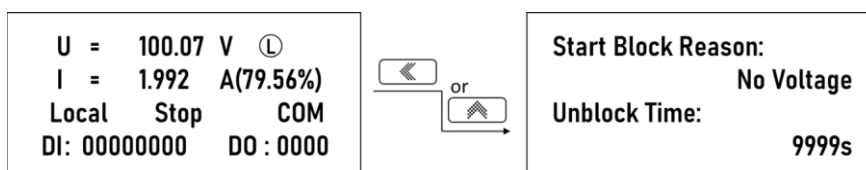

Figure 3-2 Front Panel Default Display and Motor Start Block Screens

If there is no Front Panel activity for 3 minutes or longer, the LCD will return to the Default Display.

3.4.2 Main Menu

Pressing the <Setup> button will enter the Main Menu screen. The main menu consists of 8 items, **Metering**, **DI/DO**, **View Para.**, **Logs**, **Setup**, **Statistic**, **Maint.**, and **Info**. Each item consists of sub-menus for detailed data viewing or setup configurations. All data and setup parameters can be viewed without a password, but a valid Front Panel Password is required for making setup changes. The default Front Panel Password is "0000".

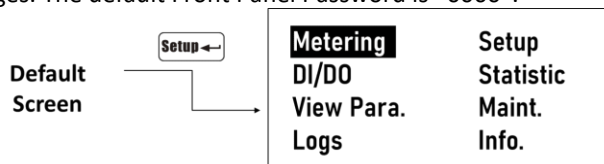

Figure 3-3 Front Panel Main Menu screen

The following section illustrates the available measurements or parameters for each menu.

3.4.3 Metering

The **Metering** menu consists of **Relay Data**, **Metering Data** and **Harmonic**. The following sections provide a quick overview for these screens.

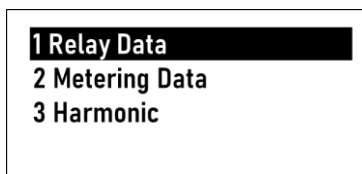

Figure 3-4 Metering menu

3.4.3.1 Relay Data

Enter the **Relay Data** sub-menu and the following screens are available.

IA 7.000 A 30.0° IB 7.500 A 270.0° IC 8.000 A 150.0°	IA 700.00 %le IB 750.00 %le IC 800.00 %le IR 1000 mA	P 600.00 kW Q 500.00 kvar PF 0.768 I Unbalance 20.00%
UAB 140.00 V 0° UBC 150.00 V 240.0° UCA 160.00 V 120.0° f 50.00 Hz	I1 5.500A I2 6.000A 3I0 5.000A	Cooling Time 60.0s Heat Capacity 50.0%

Figure 3-5 Relay Data

3.4.3.2 Metering Data

Enter the **Metering Data** sub-menu and the following screens are available.

Ia 5.000 A 30.0° Ib 5.500 A 270.0° Ic 6.000 A 150.0°	Ia 500.00 %le Ib 550.00 %le Ic 600.00 %le	Uab 100.00 V 0° Ubc 110.00 V 240.0° Uca 120.00 V 120.0°
P 750.00 kW Q 650.00 kvar PF 0.756	kWh Import 123456.78kWh kvarh Import 2.00 kvarh	kWh Export 76543.21 kWh kvarh Export 8.88 kvarh

Figure 3-6 Metering Data

3.4.3.3 Harmonic

Enter the **Harmonic** sub-menu and the following screens are available.

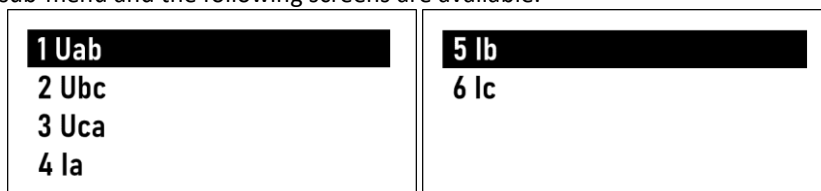

Figure 3-7 Harmonic Parameters

Press <Setup←> to view the THD, TOHD, TEHD and the Individual Harmonic measurements from 2nd to 31st for the selected Harmonic parameter.

THD	0.00 %		HD31	0.00 %
TOHD	0.00 %	...		
TEHD	0.00 %			
HD02	0.00 %			

Figure 3-8 Harmonic Measurements

3.4.4 DI/DO

The **DI/DO** menu consists of DI Status and DO Status. The following section provides a quick overview of these screens.

1 DI Status
2 DO Status

Figure 3-9 DI/DO menu

3.4.4.1 DI Status

Enter the **DI Status** sub-menu and the following screens are available. “o” means DI de-energized while “●” means DI energized.

D11	Local/Remote	●	D15	Common State	○
D12	Local Start A	○	D16	QF State	●
D13	Stop	○	D17	KMA State	●
D14	Remote Start A	○	D18	Common State	○

Figure 3-10 DI Status

3.4.4.2 DO Status

Enter the **DO Status** sub-menu and the following screen is available. “o” means DO released while “●” means DO operated.

D01	Trip Contactor	○
D02	Start A	●
D03	Trip QF	○
D04	Spare	○

Figure 3-11 DO Status

3.4.5 View Parameters

The **View Parameters** menu provides an access to check the current settings on the relay without requiring a Front Panel password. For the detailed screens, please refer to **Section 3.4.7 Setup**.

3.4.6 Logs

The Logs menu consists of **DI/DO Logs**, **Protection Logs**, **Diagnostic Logs**, **Maintenance Logs**, **Start Report** and **Stop Report**. The following section provides a quick overview of these screens.

1 DI/DO Logs	5 Start Report
2 Protection Logs	6 Stop Report
3 Diag. Logs	
4 Maint. Logs	

Figure 3-12 Logs menu

3.4.6.1 DI/DO Logs

The **DI/DO Logs** sub-menu displays the DIx Opened/Closed or DOx Act/Return events (1 event per page) with DI/DO Function and Timestamp on the Front Panel.

01 D01 Return Trip Contactor 22/06/24 11:01:20:528	02 D11 Closed Local/Remote 22/06/24 11:00:18:528
---	---

Figure 3-13 DI/DO Logs

3.4.6.2 Protection Logs

The relay supports the display of the **Protection Logs** with up to 64 events (one event per page) such as Thermal OL (Overload) Trip, Undervolt. (Undervoltage) Restart Fail, etc., with characteristics parameters and timestamp. Please refer to **Appendix A – SOE and Protection Log Classifications** for the details.

01 Thermal OL Trip IA = 2.995A IB =0.995A IC = 0.995A UAB = 98.77V UBC = 98.72V UCA =98.70V 3I0 =4.975A 22/04/13 11:30:02:104
--

Figure 3-14 Protection Logs

3.4.6.3 Diag. Logs

The **Diag. Logs** sub-menu displays the Metering Error, Device Parameters Error or other fault events defined in **Appendix A – SOE and Protection Log Classifications** with timestamp.

01 Device Para. ERR 22/07/04 14:50:18:959
--

Figure 3-15 Diag. Logs

3.4.6.4 Maint. Logs

The **Maint. Logs** sub-menu displays the device power on/off, clear operations (Energy, SOE, Statistics, etc.), manual WFR trigger and other manual operations with timestamp.

01 Manual WFR Trigger 22/07/04 14:50:09:961
--

Figure 3-16 Maintenance Logs

3.4.6.5 Start Report

The relay supports the display of **Start Report** with up to 64 start logs recording **Start Control Source, Maximum Start Current, Minimum Start Voltage, Motor Start Time, Start Result** and **Timestamp** for each motor start.

01 External Ctrl I_{max}=1.0A U_{min}=86V Start t 2.00s Succ. 22/04/13 11:01:00:364
--

Figure 3-17 Start Report

3.4.6.6 Stop Report

The relay also supports the display of **Stop Report** with up to 64 stop logs recording the **Stop Control Source**, **3-phase Currents Magnitude** and **Timestamp** for each motor stop.

01 Modbus Ctrl	
IA=0.00A	IB=0.00A
IC=0.00A	
22/04/13	18:49:25:355

Figure 3-18 Stop Report

3.4.7 Setup

The **Setup** menu consists of **System**, **Protection**, **Digital Inputs**, **Digital Outputs**, **Control**, **Communication**, **Analog Outputs** and **Data Recorder**. The following sections provide a quick overview for these screens. The **Front Panel Password** is required for any setup changes. Please refer to **Section 3.4.7.9** for the setup range and default values.

<p>1 System</p> <p>2 Protection</p> <p>3 Digital Inputs</p> <p>4 Digital Outputs</p>	<p>5 Control</p> <p>6 Communication</p> <p>7 Analog Outputs</p> <p>8 Data Recorder</p>
---	---

Figure 3-19 Setup menu

3.4.7.1 System

Enter the **System** sub-menu and the following screens are available.

MTA Connected YES	Primary Ue 100V
MTA Type 5	Secondary Ue 100V
Phase TA Ratio 1	Ctrl Key Emergency
Ie 1.0A	DO Remote OFF
Language English	Voltage Sequence ABC
Ia Polarity Normal	Current Sequence ABC
Ib Polarity Normal	PLC ON
Ic Polarity Normal	

Figure 3-20 System Setup Screens

3.4.7.2 Protection

Enter the **Protection** sub-menu to configure the Trip/Alarm Reset Mode for all protections, the Pickup, Time Delay, Supplementary Outputs and other settings for each protection as well as block a specific protection when motor starts. Please refer to Table for setup range and the default values.

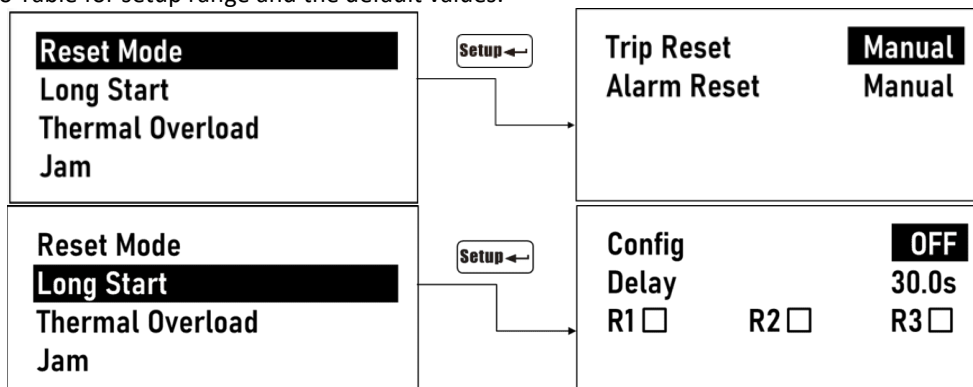

Figure 3-21 Protection Setup Screens

3.4.7.3 Digital Inputs

Enter the **Digital Inputs** sub-menu to configure the **DI Mode**, **Type**, **Debounce Time** and **Excitation** for each DI.

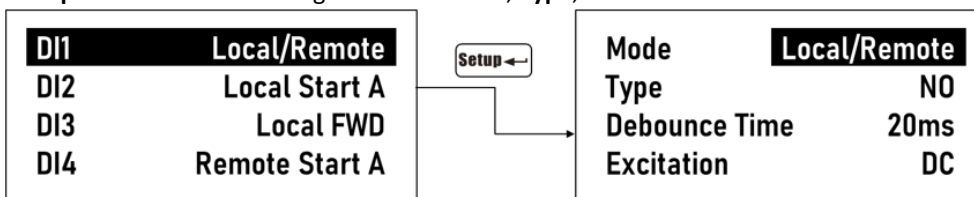

Figure 3-22 Digital Inputs Setup Screens

3.4.7.4 Digital Outputs

Enter the **Digital Outputs** sub-menu to configure the **DO Mode** and **Delay** for each DO.

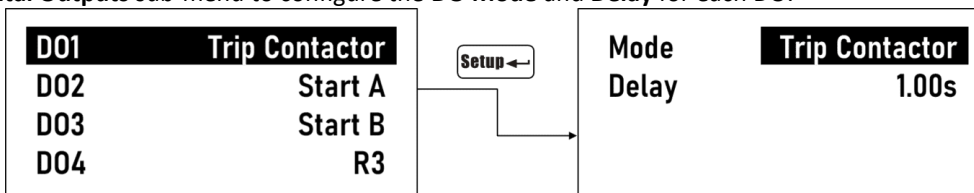

Figure 3-23 Digital Outputs Setup Screens

3.4.7.5 Control

Enter the **Control** sub-menu to configure the parameters for **Undervoltage Restart**, **Auto-Restart**, **Start Control**, **Start-Stop Type** and select the **Control Mode**.

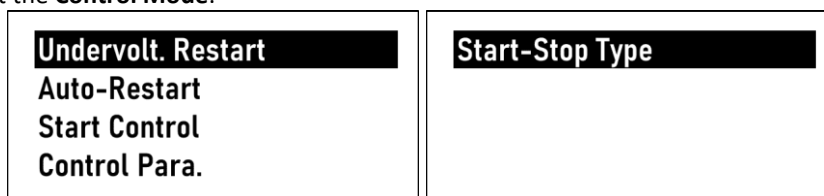

Figure 3-24 Control Setup Screens

3.4.7.6 Communications

Enter the **Communications** sub-menu to configure the parameters for Modbus or Profibus-DP communications.

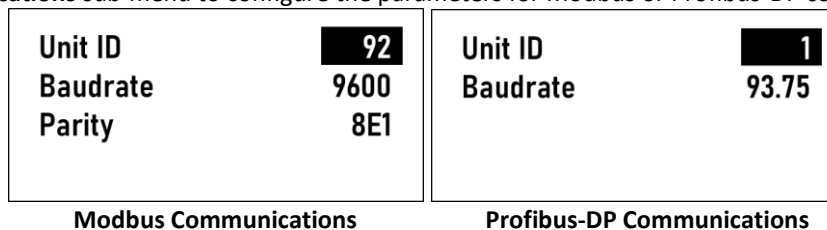

Figure 3-25 Communications Setup Screens

3.4.7.7 Optional Analog Outputs

Enter the **Analog Outputs** sub-menu and the following screen is available.

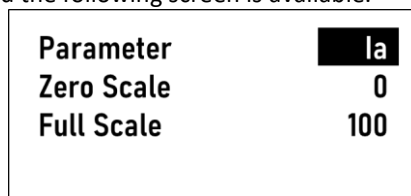

Figure 3-26 Optional Analog Outputs Setup Screen

3.4.7.8 Data Recorder

Enter the Data Recorder sub-menu to configure the **Record Mode**, **Start Mode** and **Interval**.

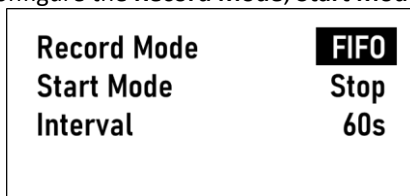

Figure 3-27 Data Recorder Setup Screen

3.4.7.9 Configuration Parameter

The **Setup** menu provides access to the following setup parameters:

Main Menu			Description	Option/Range, Default*
1 st	2 nd	3 rd		
Password			Enter Password	0000 to 9999, 0000*
System				
	MTA Connected		Confirm if the PMC-MTA connected	Yes*, No
	MTA Type ¹		The primary rating of the connected PMC-MTA	1 to 5000 (A), 100*
	Phase TA Ratio ²		Phase TA ratio, if used	1 to 5000, 1*
	Ie ³		Rated motor current	0.1 to 6000.0 (A), 100.0*
	In TA Type**		The primary rating of the connected PMC-MIN	1 or 5 (A), 5*
	In TA Ratio**		IN TA Ratio, if used	1 to 1000, 40*
	Primary Ue		Rated motor voltage (ULL)	100 to 800 (V), 380*
	Secondary Ue		Rated relay voltage (Ull)	100 to 800 (V), 380*
	Ctrl Key		Specify if the Front Panel control button operational under different control mode, see Note 4	Disable*/Emergency/Local/Remote
	DO Remote		Specify if the DO needs to be “armed” before executing, ON – need to be “armed”, OFF – no need	OFF*, ON
	Language		Select the Front Panel Display Language	Chinese, English*
	Ia Polarity		Ia Polarity	Normal*/Reverse
	Ib Polarity		Ib Polarity	
	Ic Polarity		Ic Polarity	
	Voltage Sequence		Adjust the Voltage Sequence	ABC*/CBA
	Current Sequence		Adjust the Current Sequence	ABC*, CBA, ACB, CAB, BAC, BCA
	PLC		Enable Programmable Logic or not	OFF, ON*
Protection				
	Reset Mode ⁵		Specify the generic reset mode for protection (except for Thermal Overload) relay output	
	Trip Reset		Specify the reset mode for relay Trip output	Manual*/Auto
	Alarm Reset		Specify the reset mode for relay Alarm output	Manual/Auto*
	Long Start			
	Config		Specify the protection output type	OFF*, Trip, Alarm, Trip + Alarm
	Delay		Specify the protection active delay	0.1 to 99.9 (s), 30.0*
	R1 R2 R3		Select the supplementary output to be linked	N/A
	Thermal Overload			
	Config		Specify the protection output type	OFF, Trip, Alarm, Trip + Alarm*
	Pickup		Specify the protection active threshold (Iov)	1.00 to 10.00 (xIe), 1.00*
	Delay		Specify the Heating Time Constant (Tc)	0.1 to 99.9, 6.5*
	Cooling		Specify the cooling method after protection returns	Instant, Delay*
	Pre-Alarm Trig.		Specify the Thermal Pre-Alarm threshold (of operation level)	0 to 100 (%), 0*
	Return Threshold		Specify the protection return threshold (valid only when Cooling method is set to Delay)	0 to 100 (%), 60*
	Reset Mode ⁵		Specify the reset mode for protection output	Manual*/Auto
	R1 R2 R3		Select the supplementary output to be linked	N/A
	Jam			
	Config		Specify the protection output type	OFF*, Trip, Alarm, Trip + Alarm
	Pickup		Specify the protection active threshold	1.0 to 10.0 (xIe), 3.5*
	Delay		Specify the minimum time duration that the fault condition must be met before the protection become active	0.1 to 99.9 (s), 4.0*
	R1 R2 R3		Select the supplementary output to be linked	N/A
	Ground Fault			
	Config		Specify the protection output type	OFF, Trip, Alarm, Trip + Alarm*
	Type		Select the monitored Ground Fault current type	3I0 (Measured)*, In

CET Electric Technology

Pickup	Specify the protection active threshold	0.1 to 10.0 (xIe), 1.0*
Run Delay	Specify the minimum time duration that the fault condition must be met before the protection become active when motor is running	0.0 to 99.9 (s), 0.1*
Start Delay	Specify the minimum time duration that the fault condition must be met before the protection become active when motor is starting	0.00 to 99.99 (s), 0.50*
R1 R2 R3	Select the supplementary output to be linked	N/A
MTA Failure		
Config	Enable/Disable MTA Failure Alarm	OFF*, ON
Delay	Specify the minimum time duration that the fault condition must be met before the protection become active	0.1 to 99.9 (s), 0.5*
R1 R2 R3	Select the supplementary output to be linked	N/A
Phase Current Loss		
Config	Specify the protection output type	OFF, Trip, Alarm, Trip + Alarm*
Delay	Specify the minimum time duration that the fault condition must be met before the protection become active	0.1 to 99.9 (s), 2.5*
Block MTA Failure	Block Phase Current Loss element if MTA Failure detected	OFF*, ON
R1 R2 R3	Select the supplementary output to be linked	N/A
Imbalance		
Config	Specify the protection output type	OFF, Trip, Alarm*, Trip + Alarm
Pickup	Specify the protection active threshold	10 to 100 (%), 30*
Block Value	Imbalance current threshold for blocking current imbalance detection	0 to 0.80 (Ie), 0.25*
Delay	Specify the minimum time duration that the fault condition must be met before the protection become active	0.1 to 99.9 (s), 5.0*
Block MTA Failure	Block Imbalance element if MTA Failure detected	OFF*, ON
R1 R2 R3	Select the supplementary output to be linked	N/A
Under Power		
Config	Specify the protection output type	OFF*, Trip, Alarm, Trip + Alarm
Pe	Rated motor power	0.1 to 999.9 (kW), 75.0*
Pickup	Specify the protection active threshold	0.10 to 0.95 (xPe), 0.40*
Block Value	Low Voltage threshold for blocking Under Power detection	0.30 to 0.95 (xUe), 0.60*
Delay	Specify the minimum time duration that the fault condition must be met before the protection become active	0.5 to 99.9 (s), 5.0*
Reset Delay	Specify the minimum time delay after which the triggered protection trip output will automatic reset	0.0 to 6000.0 (s), 0.0*
R1 R2 R3	Select the supplementary output to be linked	N/A
Short Circuit		
Config	Specify the protection output type	OFF, Trip, Alarm, Trip + Alarm*
Pickup ⁶	Specify the protection active threshold	1.0 to 10.0 (xIe), 7.5*
Delay	Specify the minimum time duration that the fault condition must be met before the protection become active	0.0 to 99.9 (s), 0.0*
Start Multiple ⁶	Specify the Start Multiple to decrease the fault detection sensitivity in motor start period	1.00 to 2.00, 1.00*
R1 R2 R3	Select the supplementary output to be linked	N/A
Undervoltage		
Config	Specify the protection output type	OFF*, Trip, Alarm, Trip + Alarm
Pickup	Specify the protection active threshold	0.30 to 0.95 (xUe), 0.45*
Delay	Specify the minimum time duration that the fault condition must be met before the protection become active	0.1 to 99.9 (s), 9.0*
No_I Lock	Lock/Unlock Undervoltage protection when $I_e=0$ detected	OFF, ON*
Reset Delay	Specify the minimum time delay after which the triggered protection trip output will automatic reset	0.0 to 6000.0 (s), 0.0*
R1 R2 R3	Select the supplementary output to be linked	N/A
Overvoltage		
Config	Specify the protection output type	OFF*, Trip, Alarm, Trip + Alarm
Pickup	Specify the protection active threshold	1.05 to 1.60 (xUe), 1.20*
Delay	Specify the minimum time duration that the fault condition must be met before the protection become active	0.1 to 99.9 (s), 4.0*
R1 R2 R3	Select the supplementary output to be linked	N/A
Underload		
Config	Specify the protection output type	OFF*, Trip, Alarm, Trip + Alarm

CET Electric Technology

Pickup	Specify the protection active threshold	0.10 to 1.00 (xle), 0.40*
Delay	Specify the minimum time duration that the fault condition must be met before the protection become active	1 to 9999 (s), 20*
Reset Delay	Specify the minimum time delay after which the triggered protection trip output will automatic reset	0.0 to 6000.0 (s), 0.0*
R1 R2 R3	Select the supplementary output to be linked	N/A
tE Time		
Config	Specify the protection output type	OFF*, Trip, Alarm, Trip + Alarm
Delay	Specify the time constant Tp	0.1 to 99.9 (s), 6.0*
R1 R2 R3	Select the supplementary output to be linked	N/A
Overload		
Config	Specify the protection output type	OFF*, Trip, Alarm, Trip + Alarm
Pickup	Specify the protection active threshold	1.0 to 10.0 (xle), 1.2*
Delay	Specify the minimum time duration that the fault condition must be met before the protection become active	0.1 to 99.9 (s), 30.0*
R1 R2 R3	Select the supplementary output to be linked	N/A
Interlock		
Config	Specify the protection output type	OFF*, Trip, Alarm, Trip + Alarm
Delay	Specify the minimum time duration that the fault condition must be met before the protection become active	0.1 to 99.9 (s), 0.2*
R1 R2 R3	Select the supplementary output to be linked	N/A
LOP		
Config	Enable/Disable Loss of Phase alarm	OFF, ON*
R1 R2 R3	Select the supplementary output to be linked	N/A
Phase Reversal		
Config	Specify the protection output type	OFF*, Trip, Alarm, Trip + Alarm
R1 R2 R3	Select the supplementary output to be linked	N/A
CB Failure		
Config	Specify the protection output type	OFF*, Trip, Alarm, Trip + Alarm
Delay	Specify the minimum time duration that the fault condition must be met before the protection become active	0.1 to 99.9 (s), 1.0*
R1 R2 R3	Select the supplementary output to be linked	N/A
Contactor		
Config	Enable/Disable Contactor protection	OFF*, ON
Pickup	Contactor maximum breaking capacity	4.0 to 20.0 (xle), 8.0*
Contactor Failure		
Config	Enable/Disable Contactor Failure alarm	OFF*, ON
Pickup	Specify the protection active threshold	0.1 to 5.0 (xle), 0.3*
Delay	Specify the minimum time duration that the fault condition must be met before the protection become active	0.1 to 99.9 (s), 0.5*
Stop Trigger	Enable/Disable Contactor Failure protection after motor stop command sent	OFF, ON*
R1 R2 R3	Select the supplementary output to be linked	N/A
ACB Ctrl Contactor		
Config	Enable/Disable Air Circuit Breaker Control Contactor feature	OFF*, ON
Delay	Specify the minimum time duration that the fault condition must be met before the protection become active	0.1 to 99.9 (s), 1.0*
Contactor Abnormal		
Config	Specify the protection output type	OFF*, Trip, Alarm, Trip + Alarm
Delay	Specify the minimum time duration that the fault condition must be met before the protection become active	0.1 to 99.9 (s), 5.0*
R1 R2 R3	Select the supplementary output to be linked	N/A
Emergency Stop		
Config	Enable/Disable Emergency Stop alarm	OFF*, ON
R1 R2 R3	Select the supplementary output to be linked	N/A
Residual Current		
Config	Specify the protection output type	OFF*, Trip, Alarm, Trip + Alarm
Trip Pickup	Specify the protection Trip threshold	20 to 5000 (mA), 500*
Alarm Pickup	Specify the protection Alarm threshold	20 to 5000 (mA), 300*
Trip Delay	Specify the minimum time duration that the Trip condition must be met before the protection trips	0.0 to 99.9 (s), 1.0*
Alarm Delay	Specify the minimum time duration that the Alarm condition must be met before the protection alarms	0.0 to 99.9 (s), 5.0*

Start Multiple	Specify the Start Multiple to decrease the fault detection sensitivity in motor start period	1.00 to 2.00, 1.00*
R1 R2 R3	Select the supplementary output to be linked	N/A
Negative Sequence		
Config	Specify the protection output type	OFF*, Trip, Alarm, Trip + Alarm
Pickup	Specify the protection active threshold	0.1 to 10.0 (Ie), 1.2*
Run Delay	Specify the minimum time duration that the fault condition must be met before the protection become active when motor is running	0.1 to 99.9 (s), 2.0*
Start Delay	Specify the minimum time duration that the fault condition must be met before the protection become active when motor is starting	0.1 to 99.9 (s), 4.0*
R1 R2 R3	Select the supplementary output to be linked	N/A
Block When Start		
Block Time	Specify the block time for the inhibited protection	0.0 to 99.9 (s), 10.0*
Select	Check/Uncheck on a specified protection during motor start	See Note 7, N/A
Digital Inputs		
DI1 to DI8		
Mode	Specify the DI function based on the application	See Note 8, Common State*
Type	Specify the de-energized position for the contacts of a certain DI. NO – Normally Open, NC – Normally Closed.	NO*, NC
Debounce Time	Specify the minimum duration the DI must remain in the Active or Inactive state before a state change is valid.	20 to 9999 (ms), 40*
Excitation	Specify the excited mode for each DI.	DC*, AC, External
Digital Output		
DO1 to DO5		
Mode	Specify the DO function based on the application	See Note 9
Delay	Specify the duration for which the relay output will be inactive when an release command is received	0.00 to 99.99 (s)
Control		
Undervolt. Restart		
Config	Enable/disable the Undervoltage restart control	OFF*, ON
Quick Start t	Allowable duration for a short voltage dip. If the voltage recovers within this time, the motor can automatically restart.	0.0 to 9.9 (s), 2.5*
Preset DO Close	ON – Keep the contact of the motor start DO closed during the short voltage dip without checking if the voltage has been restored. OFF – The motor start DO will close automatically when the voltage is restored.	ON*, OFF
Restart Delay	Minimum delay in restarting the motor after the voltage is restored.	0.1 to 999.9 (s), 0.2*
Allowed Time	The allowable time for Undervoltage Restart. This time must be longer than the sum of the Quick Start t and Restart Delay. If the voltage recovers within this time window, the motor can restart with the Undervoltage Restart logic.	0.5 to 999.9 (s), 20.0*
Dip Threshold	Voltage magnitude indicating the begin of a voltage dip	0.30 to 0.95 (xUe), 0.45*
Recover Volt.	Voltage magnitude indicating the end of a voltage dip	0.80 to 1.60 (xUe), 0.80*
Aux. DO	In soft-starter combined control applications, the auxiliary DO offer a reset signal before restarting the soft-starter if needed.	N/A*, DO1 to DO5
Aux. DO Delay	Delay in operating the auxiliary DO after the voltage is restored	0.0 to 300.0 (s), 0.0*
Pulse Width	When Pulse Width \geq Quick Start t, the DO configured for the motor running indicator will remain closed during a voltage dip	0.00 to 30.00 (s), 0.10*
Auto-Restart		
Config	Enable/Disable the Auto-Restart control	OFF*, ON
Mode	Restart – Restart the motor via DO Start A signal no matter what state it was running at before a long voltage dip. Recover – Restart the motor via DO Start B signal if motor was reversing or running at speed 2. Otherwise, restart the motor via DO Start A signal.	Restart, Recover*
Delay	The time delay until the motor is restarted or recovered after the end of a long voltage dip	0.1 to 99.99 (s), 0.1*
Start Control		
Start Lock t	Specify the minimum time window between motor starts	0 to 9999 (s), 0* (0 means disabled)

Stop Lock t	Specify the waiting time after the motor was stopped or tripped that has to pass until a safe restart is possible	0 to 9999 (s), 0* (0 means disabled)
Max. Start Count	Specify the maximum number of starts in a defined interval	0 to 20, 0* (0 means disabled)
Interval	Specify the time window during which if the Max. Start Count is reached, any additional start request will be ignored	1 to 9999 (min), 30*
Control Para.		
Mode	Select the starter type based on the application and wiring	See Note 10
Start-Stop Type		
Stop DI Trig.	Specify the Trip relay output mode for DI Stop Command	Latched*, Pulse
DP Control**		
Config	ON – PROFIBUS DP communication interruption will cause motor stop OFF – PROFIBUS DP communication interruption has no effect to motor running	OFF*, ON
Communication ¹¹		
RS-485		
Unit ID	Set RS-485 Unit ID	1 to 247
Baudrate	Set RS-485 Baudrate (bps)	1200, 2400, 4800, 9600*, 19200
Parity	Set RS-485 Parity	8N2, 8O1, 8E1*, 8N1, 8O2, 8E2
PROFIBUS DP**		
Unit ID	Set PROFIBUS DP Unit ID	1 to 125, 1*
Baudrate	Set PROFIBUS DP Baudrate (kbps)	9.6, 19.2, 45.45, 93.75, 187.5, 500, 1500*
Analog Output**		
Parameter	Specify the parameter to which the Analog Output is proportional	Ia*, Ib, Ic, Total kW, Ir, In
Zero Scale	Specify the zero-scale value of the parameter when the Analog Output is 4mA	-999,999 to 999,999, 40*
Full Scale	Specify the full-scale value of the parameter when the Analog output is 20mA	-999,999 to 999,999, 200*
Data Recorder		
Record Mode	Specify the DR Record Mode	Stop-when-full, First-in-first-out*
Start Mode	Specify the trigger mode for Data Recorder	Disable*, Direct, Logic
Interval	Specify the Data Recording Interval	1 to 600 (s), 60*

**Appear only if the device is equipped with the appropriate option.

Table 3-4 Front Panel Configuration Parameters

Notes:

- The following table illustrates the recommended PMC-MTA type based on the rated Current and Power.

MTA Type	Rated kW	Rated Current
PMC-MTA-1A	< 0.4 kW	0.2 – 1 A
PMC-MTA-5A	0.4 – 2.2 kW	1 – 5 A
PMC-MTA-25A	2.2 – 12.5 kW	5 – 25 A
PMC-MTA-100A	12.5 – 50 kW	25 – 100 A
PMC-MTA-300A	50 – 150 kW	100 – 300 A
PMC-MTA-400A-T	120 – 200 kW	240 – 400 A
PMC-MTA-800A-T	160 – 400 kW	320 – 800 A

Table 3-5 Recommended PMC-MTA Type

- In some applications, it is required to use an additional protection current transformer (TA) to transform the circuit current to the relay's PMC-MTA Input. And the **Phase TA Ratio** should be set based on the Primary and Secondary of the protection current transformer. For example, to protect a LV motor rated at 500kW, 1200A, the Primary Input and Secondary Output of the used protection current transformer can be 1200A, 5A, respectively. The **Phase TA Ratio** should be set as $(1200A/5A) = 240$. Please note that **MTA Type** x **Phase TA Ratio** ≤ 5000.
- The following table illustrates that the motor rated Current **Ie** has a setting range based on **Z = MTA Type** x **Phase TA Ratio**.

Z	Ie Setting Range
< 100	0.1 – 1.2 (*Z)
≥ 100	0.2 – 1.2 (*Z)

Table 3-6 Motor Rated Current Ie Setting Range

- The user can use the push buttons on the Front Panel to start/stop the motor based on the **Control Key** and **DI Local/Remote** control switch settings. If the **Control Key** is set to **Disable**, the pushbuttons are not operational. **Control Key** set to **Emergency** means the pushbutton control is always valid regardless of the **DI Local/Remote** control switch setting. And under other circumstances, the **Control Key** setting has to be consistent with the **DI Local/Remote** control switch to make the pushbuttons functional. If none of DI is configured as **Local/Remote** control

switch, the **Control Key** has to be set to Local so that the Front Panel control can make sense.

- For **Auto** reset type, the protection trip/alarm is acknowledged without intervention of a human operator if the fault is removed. For **Manual** reset type, the protection trip/alarm must be acknowledged from the user via the Reset button on the Front Panel, **DI Reset Protection** control signal or through communications. **Manual** resets are used in applications and process demanding safety checks before starting process. In such application, human intervention is the final check.
- For Short Circuit protection, **Pickup x Start Multiple** ≤ 10 x **MTA Type x TA Ratio**.
- The following protection can be blocked since the motor start detected.

ID	Protection	ID	Protection	ID	Protection	ID	Protection
1	Thermal Overload	5	Imbalance	9	Overload	13	Negative Sequence
2	Jam	6	Under Power	10	Underload		
3	Ground Fault	7	Interlock	11	tE Time		
4	Phase Current Loss	8	Short Circuit	12	Phase Reversal		

Table 3-7 Protections to be Blocked when Motor Start

- The following table illustrates all the available options for DI Mode.

No.	Option	No.	Option	No.	Option	No.	Option
0	Common State	6	Remote Start B	12	Start Block	18	Emergency Start A
1	Local/Remote	7	Local Start A	13	Remote Stop	19	Emergency Start B
2	Interlock	8	Local Start B	14	Local Stop	20	Local FWD
3	Stop	9	KMA State	15	Reset Protection	21	Local REV
4	Emergency Stop	10	KMB State	16	Remote FWD	22	FWD
5	Remote Start A	11	QF State	17	Remote REV	23	REV

Table 3-8 DI Mode Options

- The following table illustrates all the available options for DO Mode.

No.	Option	No.	Option	No.	Option	No.	Option
0	Spare	3	Start A	6	Trip Air Circuit Breaker	9	R2
1	Trip Contactor	4	Start B	7	Trip Cooler/S-Motor	10	R3
2	Self-check	5	Alarm	8	R1	11	Motor Running

Table 3-9 DO Mode Options

The default setting for DO1 to DO5 Mode are:

DO1=Trip Contactor, DO2=Self-check, DO3=Start A, DO4= Trip Air Circuit Breaker, DO5= Alarm

- The following table illustrates the configuration parameters under different Starter Mode.

Setting Parameter	Specifications/Definitions	Range/Default*
Mode	Defines the starter function based on the applications.	Direct-on-line*, Reduce-volt., FWD/REV Start, 2-Speed Start, VFD Start, L-Motor Start
Reduce-Voltage Start (Including Star-Delta Start, Autotransformer Start and Resistance Start)		
Delay	Time delay in switching the motor to full-voltage running from the reduce-voltage start. The switch over from reduce-volt. start to full-volt. running takes place earliest after 1s delay. Therefore, the delay must be set to at least 1s.	1.0 to 99.9 (s), 25.0
Iset	Specify the max. allowable current for a reduced-voltage start period. If Iset=0, the motor switches to full-volt. running from the Reduced-voltage start once the Delay time is reached.	0.0 to 3.0 (xle), 0*
Start Mode	In make-before-break (MBB) mode, DO configured for Start A (Reduced-voltage) maintains closed until the DO for Start B (full-voltage) operates. While in break-before-make (BBM) mode, DO configured for Start B operates after 1s delay since the DO for Start A release. If motor $I_e < 0$ ($I_e \neq 0$) is detected after DO for Start A released, the relay will alarm that the Reduced-voltage start is failed. Please note that make-before-break mode shall not be used in Star-Delta start.	MBB, BBM*
FWD/REV Start		
Delay	Specify the minimum time before a start in the opposite direction is possible.	1.0 to 99.9 (s), 5.0*
2-Speed Start		
I1	Nominal current of motor for speed 1.	0.2 to 5.0 (xle), 1.0*
I2	Nominal current of motor for speed 2.	0.2 to 5.0 (xle), 0.5*
Delay	Specify the minimum time before a start at alternative speed is possible.	1.0 to 99.9 (s), 5.0*
VFD Start		
Delay	Specify the minimum time interval between the starts/stops of Cooler and VFD.	1.0 to 99.9 (s), 10.0*
L-Motor Start		
Delay	Specify the minimum time interval between the starts/stops of small motor and large motor.	1.0 to 99.9 (s), 10.0*

Table 3-10 Different Starter Mode Configuration Parameters

- The Communication Parameters of USB Type C port are not configurable, which are: Unit ID = 100, Baudrate = 9600, Parity = 8E1.

3.4.8 Statistics

Enter the **Statistics** menu and the following screens are available.

Trip IA	0.000A	Start I	1.210A	Total Running Time	
Trip IB	0.000A	Start Time	0.12s	Running Time	20h
Trip IC	0.000A	Start Count	22		
Trip Times	0				2h
Total Stop Time		Device Running Time			
1759h		1800h			
Stop Time					
139h					

Figure 3-28 Statistics Screens

3.4.9 Maint.

The **Maint.** menu consists of **Comm. Test, Control Logic Test, Date/Time, Change Password, Clear Data, Diagnosis, Backlight Timeout, LCD Contrast, Preset Energy** and **Manual WFR Trigger**. The following sections provide a quick overview for these screens. The **Front Panel Password** is required for any maintenance operation.

1 Comm. Test 2 Control Logic Test 3 Date/Time 4 Change Password	5 Clear Data 6 Diagnosis 7 Backlight Timeout 8 LCD Contrast	9 Preset Energy 10 Manual WFR Trigger
---	---	---

Figure 3-29 Maintenance menu

3.4.9.1 Comm. Test

Enter the **Comm. Test** sub-menu and the following screens are available. Enter a specific item and the corresponding data will be uploaded to the workstation/master for communication test.

1 Relay Data 2 Metering Data 3 Harmonic 4 DI Status	5 DO Status 6 Prot. Status
---	--------------------------------------

Figure 3-30 Comm. Test

3.4.9.2 Control Logic Test

Enter the **Control Logic Test** sub-menu and the following screens are available. Enter a specific item to perform the corresponding control logic test.

1 DI 2 DO 3 Protection

Figure 3-31 Control Logic Test

3.4.9.3 Date/Time

Enter the **Date/Time** sub-menu and the following screen is available.

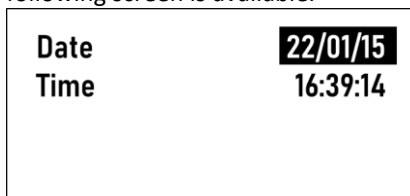

Figure 3-32 Date/Time

3.4.9.4 Change Password

Enter the **Change Password** sub-menu and the following screens are available.

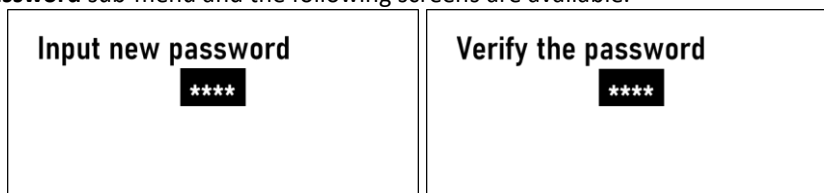

Figure 3-33 Change Password

3.4.9.5 Clear Data

Enter the **Clear Data** sub-menu and the following screens are available.

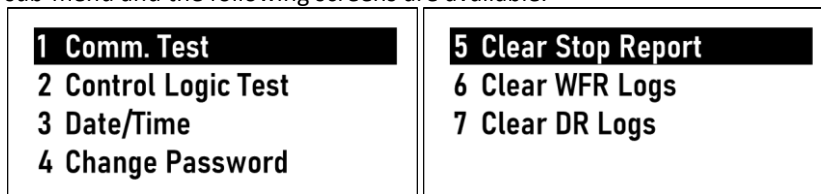

Figure 3-34 Clear Data

3.4.9.6 Diagnosis

Enter the **Diagnosis** sub-menu and the following screen is available which displays the Voltage and Current Polarity.

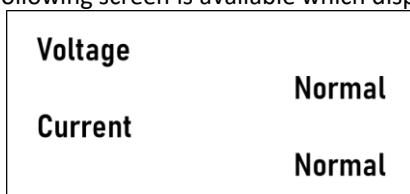

Figure 3-35 Diagnosis

3.4.9.7 Backlight Timeout

Enter the **Backlight Timeout** sub-menu to adjust the LCD timeout.



Figure 3-36 Backlight Timeout

3.4.9.8 LCD Contrast

Enter the **LCD Contrast** sub-menu and the following screen is available.

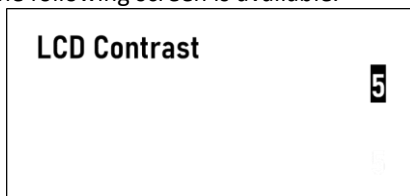

Figure 3-37 LCD Contrast

3.4.9.9 Preset Energy

Enter the **Preset Energy** sub-menu to preset the kWh Export and kvarh Export.



Figure 3-38 Preset Energy

3.4.9.10 Manual WFR Trigger

Enter the **Manual WFR Trigger** sub-menu to trigger a waveform recording.

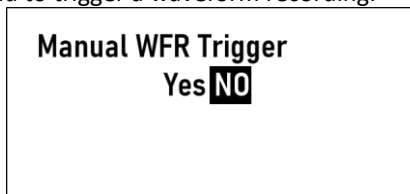

Figure 3-39 Manual WFR Trigger

3.4.10 Info.

Enter **Info.** menu to access the following device information.

Firmware	V3.00.05	PLC Version	V1.01
Modbus	V3.1		
Date	22.03.14		
S/N	1003696792		

Figure 3-40 Info.

Chapter 4 Applications

4.1 Digital Inputs

The PMC-550J comes with eight Digital Inputs, which support being either internally or externally wetted based on the model option selected.

4.1.1 Parameters

The following table describes the available setting parameters for Digital Inputs.

Parameters	Definitions	Options/Default*
DIx Mode (x=1 to 8)	Each DI can be configured as a Common State Input, Status Input or Control Signal Input (See Table 4-2). Only one DI can be configured as Local/Remote, KMA State, KMB State, or QF State . For example, if DI1 is configured for KMA State , the configuration for DI2 Mode = KMA State will be rejected.	Common state*
DIx Type	Specify the de-energized position for the contacts of a certain DI. NO – Normally Open, NC – Normally Closed.	NO*, NC
Debounce Time	Specify the minimum duration the DI must remain in the Active or Inactive state before a state change is considered to be valid.	20 to 9999 (ms), 40*
DIx Excitation	Specify the excited mode for each DI.	DC*, AC, External

Table 4-1 DI Setup Parameters

Notes:

- For internally wetted DI, the Excitation mode must be DC. However, if the user wishes to use 110VAC/DC or 220VAC/DC voltage with a PMC-KI module to excite the DI, the DI Excitation mode must be External. For externally excited DI, the Excitation mode must be AC.

4.1.2 DI Mode

The relay provides the following programmable functions for its Digital Inputs.

DI Mode	Functions/Descriptions
Common State	Common status monitoring. This mode doesn't apply to any protection or control element.
Status Input	
Local/Remote	Local and remote control switch. See Note 1.
Interlock	External control signal input. See Interlock Protection.
KMA State	The DI configured as KMA state connects to the auxiliary contacts of a contactor controlling the motor. The DI status indicates the contactor coil status, with "1" meaning energized and "0" meaning de-energized. Besides, in Large Motor control applications, this DI shall connect to the large motor circuit for status monitoring. Only one DI shall be configured as KMA State.
KMB State	The DI configured as KMB state connects to the auxiliary contacts of a contactor in a different position from the KMA contactor. The DI status indicates the contactor coil status, with "1" meaning energized and "0" meaning de-energized. Besides, in Large Motor control applications, this DI shall connect to the small motor circuit for status monitoring. Only one DI shall be configured as KMB State.
QF State	Status input for air circuit breaker. Only one DI can be configured as QF State.
Control Signal Input	
Emergency Stop	An Emergency Stop operation occurs irrespective of the control mode.
Stop	Common Stop operation occurs irrespective of the control mode.
Remote Stop	Stop operation valid only when the control mode is Remote.
Local Stop	Stop operation valid only when the control mode is Local.
Remote Start A	Start A operation valid only when the control mode is Remote.
Remote Start B	Start B operation valid only when the control mode is Remote.
Local Start A	Start A operation valid only when the control mode is Local.
Local Start B	Start B operation valid only when the control mode is Local.
Remote FWD	Forward/Speed 1 Start-Stop operation valid only when the control mode is Remote.
Remote REV	Reverse/Speed 2 Start-Stop operation valid only when the control mode is Remote.
Start Block	Block all the start signal inputs according to the applications.
Reset Protection	Reset trip or alarm output contact for protection.
Emergency Start A	Emergency Start A operation occurs irrespective of the control mode.
Emergency Start B	Emergency Start B operation occurs irrespective of the control mode.
Local FWD	Forward/Speed 1 Start-Stop operation valid only when the control mode is Local.
Local REV	Reverse/Speed 2 Start-Stop operation valid only when the control mode is Local.
FWD	Forward/Speed 1 Start-Stop operation irrespective of the control mode.
REV	Reverse/Speed 2 Start-Stop operation irrespective of the control mode.

Table 4-2 Programmable DI Mode

Notes:

- A de-energized position of DI contacts configured to **Local/Remote control switch** stands for **Local Control** mode while an energized position means **Remote Control**.

2. The Emergency Start control signals is valid only when Thermal Overload protection trips. See **Section 4.4.4.5.6**.
3. In **Forward-Reverse** and **2-speed** start, if the motor is already running in a certain direction or at a certain speed, it requires a stop signal before an opposite or alternative speed operation. For DI configured to (Local/Remote) FWD or REV, a none-zero value means Forward or Reverse (at speed 1 or speed 2 in 2-speed control) while a zero value means stop.
4. The (Local/Remote) REV control signals are only valid in forward-reverse or 2-speed control modes.
5. The following table describes the definitions for DI Start A and Start B control signals with different Starter functions based on the schematic diagrams in **Section 4.6**.

Starter Functions	DI Signals	
	Start A	Start B
Direct-On-Line	Start	-- (Not used)
Reduce-voltage	Reduce-voltage start	Full-voltage running
Forward-reverse	Forward	Reverse
2-speed	Speed 1	Speed 2
VFD start	Start VFD	-- (Not used)
L-Motor start	Start Large Motor	-- (Not used)

Table 4-3 Definitions for DI Start A/Start B Signals under Various Starter Functions

4.2 Digital/Relay Outputs

4.2.1 DO Mode

The Digital Outputs on the relay can be mapped to various protection (trip and alarm) and general-purpose control elements as the following description.

- 1) Trip Contactor Link to protection trip signal. The DO1 is set as Trip Contactor with factory configurations. As a fault output, providing **Trip Reset = Manual** (See **Section 4.4.3**), once the trip condition has cleared, the DO requires a manual reset via the Front Panel, **DI Reset Protection**, or through communications to return to inactive state from the active state, regardless the **DO Delay** setting. While in **Auto** reset mode, once the trip condition is removed, the DO will automatically return to an inactive state after a time equals to **DO Delay**. Optionally, the **Trip Contactor** output can be used for motor stop control. In such application, the DO must be released by the timer (**DO Delay**).
- 2) Self-check The DO configured for **Self-check** shall connect to the contactor controlling motor ON/OFF (usually select DO2 with NC type for Self-check output). The contact for Self-check DO will release to break the motor circuit when a self-check error occurs (see Appendix A for the self-check type details). The **DO Delay** should be set to **Latched** mode (i.e., Delay = 0).
- 3) Start A The DO Start A links to different start operations depending on the Starter functions (see **Table 4-5**). The DO3 is configured as Start A by default. To use the same Do for start and stop control, the **DO Delay** should be set to **Latched** mode (i.e., Delay = 0).
- 4) Start B The DO Start B links to different start operations depending on the Starter functions (see **Table 4-5**). To use the same DO for start and stop control, the **DO Delay** should be set to **Latched** mode (i.e., Delay = 0).
- 5) Alarm Link to the protection alarm signal. The DO5 is configured as an Alarm output by default for selected protection elements such as Thermal Overload, Ground Fault, and Short Circuit. As a fault output, providing **Alarm Reset = Manual** (See **Section 4.4.3**), once the alarm condition has cleared, the DO requires a manual reset via the HMI module, **DI Reset Protection**, or through communications to return to inactive state from active state, regardless the **DO Delay** setting. While in **Auto** reset mode, once the alarm condition is removed, the DO will automatically return to an inactive state after a time equal to **DO Delay**.
- 6) Trip ACB The DO configured as Trip ACB (Air Circuit Breaker) is connected to the shunt trip coil of the air circuit breaker. The DO4 is configured as Trip ACB by default for Contactor protection and Contactor Failure protection elements.
- 7) Trip Cooler/S-Motor During VFD (Variable Frequency Drive) start process, the DO with such configuration will trip the cooler. And in the Large Motor start process, the DO with such configuration will trip the smaller Motor.
- 8) R1/R2/R3 Supplementary outputs. Every protection may be allocated with R1, R2, R3 outputs or a combination thereof. When the protection operates, the DO configured as supplementary output will act without affecting the trip output or alarm output.

- 9) Motor Running Connected to the DCS system to indicate the motor running state. The DO for Motor Running (usually NO type) is energized when the motor is running. If a motor stops due to a short voltage dip, the output can be optionally closed during the voltage dip (see **Preset DO Close** in **Section 4.6**).

4.2.2 Parameters

The following table describes the general setting parameters for Digital Output.

Setting Parameter	Range	Default
DOx Mode	0=Spare, 1=Trip Contactor, 2=Self-check, 3=Start A, 4=Start B, 5=Alarm, 6=Trip Air Circuit Breaker, 7=Trip Cooler/S-Motor, 8=R1, 9=R2, 10=R3, 11=Motor Running	DO1=Trip Contactor, DO2=Self-check, DO3=Start A, DO4= Trip Air Circuit Breaker, DO5= Alarm
DOx Delay	0.00 to 99.99 (s)	1.00

Table 4-4 Digital Output Setting Parameters

No.	Option	No.	Option	No.	Option	No.	Option
0	Spare	3	Start A	6	Trip Air Circuit Breaker	9	R2
1	Trip Contactor	4	Start B	7	Trip Cooler/S-Motor	10	R3
2	Self-check	5	Alarm	8	R1	11	Motor Running

Notes:

- Depending on the Delay setting, the DO may behave differently. For **Latched** operation (**Delay = 0**), the DO will remain active when it is operated and will only return to inactive state when it's manually released. For **Pulsed** operation (**Delay ≠ 0**), the DO will return automatically from the active state to the inactive state after a duration equals to the delay without requiring a manual Release operation.
- The following table describes the definitions for **DO Start A** and **Start B** operations with different Starter functions based on the schematic diagrams in **Section 4.6**.

Control Functions	DO Operations	
	Start A	Start B
Direct-On-Line	Start	-- (Not used)
Reduce-voltage	Reduce-voltage start	Full-voltage running
Forward-reverse	Forward	Reverse
2-speed	Speed 1	Speed 2
VFD start	Start VFD	Start Cooler
L-Motor start	Start Large Motor	Start Small Motor

Table 4-5 Definitions for DO Start A/Start B Operations under Various Control Functions

4.2.3 Non-Fail-Safe Mode

During normal operation, the DO contact coil is operational. When the relay voltage is removed, the output contact is latched in a de-energized state, and the protected motor remains unprotected, referred to as **Non-Fail-Safe** mode.

When the relay voltage returns, a previously operated DO configured for Trip/Alarm and Supplementary Outputs will be energized again within 1s. Meanwhile, the DO configured for other purposes (e.g., Start A, Motor Running) remains de-energized, regardless of its previous state before the voltage interruption.

4.3 Optional Analog Output

The relay comes optionally with one analog output in the range of 4mA to 20mA. Connect the external analog input of DCS or Panel Meter to the relay output generating a DC signal proportional to a selected analog metering in the relay.

The following table describes the setting parameters for Analog Output.

Setting Parameter	Definitions	Range/Default*
AO_Zero	Defines the zero-scale value of the parameter when the analog output is 4mA.	-999,999 to 999,999 40*
AO_Full	Defines the full-scale value of the parameter when the analog output is 20mA.	-999,999 to 999,999 200*
AO_Key	Defines the parameter to which the analog output is proportional.	Ia*, Ib, Ic, Total kW, Ir, In

Table 4-6 Analog Output Setting Parameters

For example, an AO of 4-20mA is required to be proportional to Phase A Current (Ia). The maximum value of Ia is 2000A, and the minimum value is 500A. As such, the AO_Key parameter should be programmed with Ia. The AO_Zero and AO_Full parameters should be programmed with the value 500 and 2000, respectively. Therefore, when Phase A Current is 500A or below, the AO output is 4mA. When Phase A Current is 2000A, the AO output is 20mA. When Phase A Current is 1250A, the AO is $(1250A-500A) \times (20mA-4mA) / (2000A-500A) + 4mA = 12 (mA)$.

NOTE: Connection of DC voltage to the analog output terminals could result in damage to the relay!

4.4 Protection Overview

The relay realizes different protections based on the judgement for various operating conditions and the measurements in the operating process of the motor to ensure motor is running safely.

4.4.1 Motor States

The relay considers the motor is operating as soon as the current exceeding 7% of I_e (motor rated Current) is detected in the motor circuit for longer than 50ms. This criterion is referred as $I_e < 0$ ($I_e \neq 0$) in the following sections.

Two operation states are considered, **Start** and **Running** states.

4.4.1.1 Start State

The initial state of a motor is stop (See **section 4.4.1.3** for stop criteria). The relay considers a motor starting from stop based on any of the following criteria:

- 1) A change (from open to close) in the interruption device (main contactor or circuit breaker) position is detected.
- 2) The maximum value of 3-phase current, I_{max} , satisfied either of the following conditions:
 - a) Exceeds starting current threshold (Default: $1.1I_e$) for longer than 20ms.
 - b) Meets $I_e < 0$ ($I_e \neq 0$) criteria for an extended period of 100ms.

In order to help the user in the maintenance of the electrical process, the relay provides the **Last Start Current**, **Last Start Time**, **Start Count** and other statistics (See **Section 4.11.2**) which are retrievable via Front Panel or through Communications.

4.4.1.2 Running State

The relay considers a motor transition to running state based on the following criteria:

- 1) The interruption device (main contactor or circuit breaker) remains a closed position.
- 2) The maximum current, I_{max} ,
 - a) Falls below starting current return threshold (Default: $1.1I_e$) for condition a) in Starting detection criteria above with a minimum duration (Default: 2s)
 - b) Rises but still retains below $1.1I_e$ for at least 80ms for condition b) in Starting detection criteria above.

The following figure illustrates two cases of transition between starting and running processes.

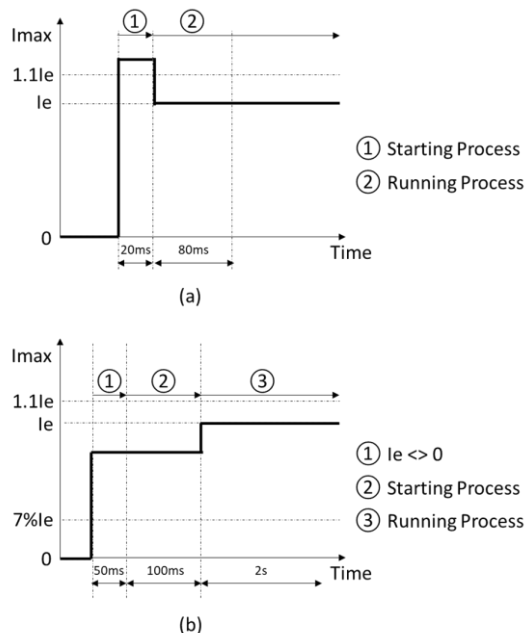

Figure 4-1 Transition between Starting and Running Processes

4.4.1.3 Stop State

The relay considers a motor as having no current flow across as soon as I_{max} falls below 6% of I_e in the motor circuit for longer than 50ms. This criterion is referred to as $I_e = 0$ in the following sections.

In either of the following circumstances, the motor is considered as completely stopped.

- 1) A change from (from close to open) in the interruption device position is detected.

2) Maximum current metering satisfied $I_e = 0$ threshold for an extended period of 80ms.

4.4.2 Protection and Motor State

4.4.2.1 Available Protection in Motor Start and Running State

As indicated in the following table, every protection element may work in different state (start state or running state).

Protection Function	Start State	Running State
Long Start protection	√	--
Thermal Overload protection	√	√
Jam protection	--	√
Ground Fault protection	√	√
MTA Failure	√	√
Phase Current Loss protection	√	√
Imbalance protection	√	√
Under Power protection	--	√
Short Circuit protection	√	√
Undervoltage protection	√	√
Overvoltage protection	√	√
Underload protection	--	√
tE Time protection	--	√
Overload protection	--	√
Interlock	√	√
LOP protection	√	√
Phase Reversal protection	√	√
Contactors protection	√	√
Emergency Stop alarm	√	√
Contactors Failure protection	√	√
ACB Control Contactors	√	√
Residual Current protection	√	√
Negative Sequence protection	√	√
CB Failure protection	√	√
Contactors Abnormal protection	√	√
Block When Start protection	√	√

"√" indicates that protection function is **Available**, "--" indicates protection function is **Not Available**.

Table 4-7 Processing of Protections in start state and running state

4.4.2.2 Block Protection When Motor Start

The following table describes the protections can be inhibited to avoid nuisance alarm or trip with specified **Block Time** counted from motor starting.

Parameters	Range	Default
Block Time	0 to 99.9 s (0 means disabled)	10.0 s
Select	Thermal Overload, Jam, Ground Fault, Phase Current Loss, Imbalance, Under Power, Interlock, Short Circuit, Residual Current, Overload, Underload, tE time, Phase Reversal, Negative Sequence Current	N/A

Table 4-8 Block When Start Setting Parameters

4.4.3 Protection Reset Mode

The protection fault output can be programmed to be reset with either **Automatic** or **Manual** type.

For **Automatic** reset type, the protection trip/alarm is acknowledged without the intervention of a human operator if the fault is removed.

For **Manual** reset type, the protection trip/alarm must be acknowledged from the user via the Reset button on the Front Panel, **DI Reset Protection** control signal or through communications. Manual reset are used in applications and process demanding safety checks before starting process. In such application, human intervention is the final check.

4.4.4 Mechanical Protection and Control

4.4.4.1 Start Control

4.4.4.1.1 Overview

➤ Start Inhibit

Repeat starting or intermittent motor operation will damage the motor and the whole network. Thus, any motor has a restriction on the number of starts that are allowed in a defined time window. When the protected motor is rated for a

minimum time between starts or a specific maximum number of starts in a defined period, set the **Start Block Time**, **Max. Start Count** and **Interval** accordingly.

If the motor is stopped or tripped within the **Start Block Time**, the relay will prevent a new start until **Start Block Time** is reached after the most recent start.

Suppose the relay detects that the **Max. Start Count** has been reached within the preset **Interval**, and the motor is already stopped or tripped, the relay will ignore any further start request until the time equal to the **Interval** has elapsed, counting from the oldest start.

➤ **Anti-backspin Lockout**

In some pump motor applications, fluid flowing backward through the pump may spin the motor after the motor is stopped. Any attempt to start the motor during this time can be damaging.

To prevent motor starts during the backspin period, the **Stop Lock Time** shall be set to define the waiting time after the motor was stopped or tripped that has to pass until a safety restart is possible.

4.4.4.1.2 Start Control Setting

The following table describes the range and default values of the setting parameters for Start Control.

Setting Parameter	Range	Default
Start Block Time	0 to 9999 s (0 means disabled)	0
Stop Block Time	0 to 9999 s (0 means disabled)	0
Max. Start Count	0 to 20 (0 means disabled)	0
Interval	1 to 9999 min	30

Table 4-9 Setting Parameters for Start Control

4.4.4.2 Start Block

Under any of the following circumstances, the relay will block the motor start request.

- 1) The motor is already in the start or running state
- 2) **Self-check** error (see **Section 4.12**)
- 3) Any protection alarm or trip occurs
- 4) **DI Start Block** signal received
- 5) **Start Control Block Time** block start period
- 6) **DI Stop** signal received

The **Start Block Reason** and **Remaining Lock Time** will be displayed on the HMI display module.

4.4.4.3 Long Start

4.4.4.3.1 Overview

If the motor fail to transmit from starting process to running state (See **Section 4.4.1 Motor States**) within the specified time delay, the Long Start protection element will issue an alarm and/or trip the contactor depending on the configurations.

The logic diagram of Long Start Protection is illustrated as the following figure.

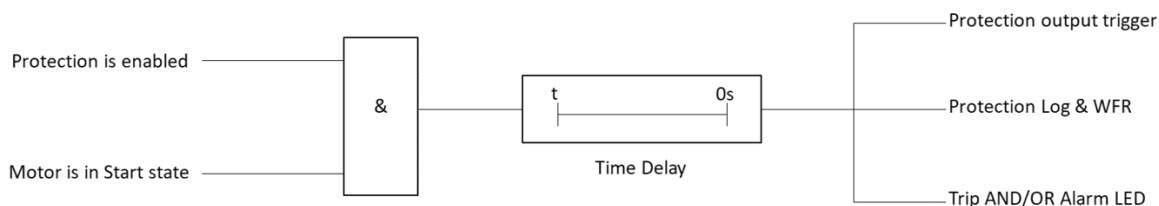

Figure 4-2 Logic Diagram of Long Start Protection

4.4.4.3.2 Long Start Setting

The following table describes the range and default values of the setting parameters for Long Start protection.

Setting Parameter	Range	Default
Config	OFF, Trip, Alarm, Trip + Alarm	OFF
Delay	0.1 to 99.9 s	30.0 s
Supplementary Output	R1 <input type="checkbox"/> R2 <input type="checkbox"/> R3 <input type="checkbox"/>	N/A

Table 4-10 Long Start Protection Setting Parameters

4.4.4.4 Jam Protection

4.4.4.4.1 Overview

In the running stage, if the motor rotor is locked due to overload or mechanical malfunction, the motor is allowed to operate for a short period according to different overload capacities. However, if the related trouble can't be solved in time, the motor windings will be overheated quickly and its insulation will breakdown, leading to the motor burned down. The Jam protection is available only in running state. The difference between the Jam and Short Circuit conditions is that the motor current rises dramatically in a short time based on a steady state in the former case.

When Jam protection is enabled and the motor maximum current I_{max} exceeds the programmable threshold, I_{jam} for longer than the time delay setting, the relay issues an alarm and/or trips the contactor depending on the protection output setting. The following figure illustrates the logic diagram for Motor Jam protection.

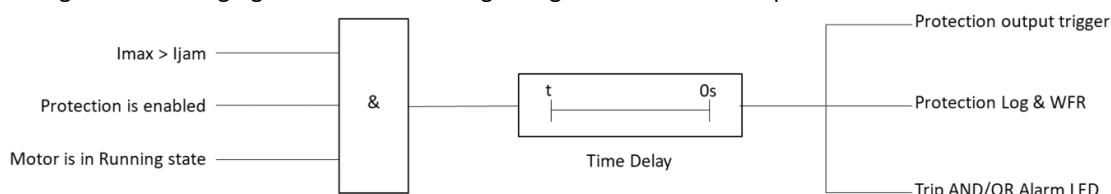

Figure 4-3 Logic Diagram of Jam Protection

4.4.4.4.2 Jam Settings

The following table describes setting range and default value for the parameters of Jam Protection.

Setting Parameter	Range	Default
Config	OFF, Trip, Alarm, Trip + Alarm	OFF
Pickup	1.0 to 10.0 (xle)	3.5
Time Delay	0.1 to 99.9 s	1.0 s
Supplementary Output	R1 <input type="checkbox"/> R2 <input type="checkbox"/> R3 <input type="checkbox"/>	N/A

Table 4-11 Jam Protection Setting Parameters

4.4.4.5 Thermal Overload Protection

The relay provides the locked rotor, running overload, and negative-sequence current imbalance protection using an inverse time thermal model. The thermal element accurately tracks the heating caused by load current and current imbalance as the motor accelerates and runs. In each case, the relay operates a thermal model with a trip value defined by the relay settings and a present heat estimate that varies with time and changing motor current. The motor's thermal estimate is expressed as **Heat Capacity** in the percentage of operation level. If the heat capacity reaches 100 percent, the protection element will issue an alarm and/or trip the contactor, depending on the protection output setting.

If the Thermal Overload protection is disabled, the relay reports the heat capacity as 0.

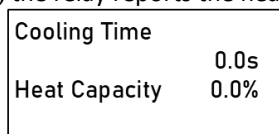

Figure 4-4 Heat Capacity Displayed on Front Panel

4.4.4.5.1 Equivalent Current

The thermal model considers the heating effect of both the positive and negative current sequences. The positive and negative current sequences are combined to form an equivalent current, I_{eq} . The equivalent current for the operation of the Thermal Overload protection is calculated with the following equation:

$$I_{eq} = \sqrt{K1 \times I1^2 + K2 \times I2^2}$$

$I1$ = Positive sequence Current

$I2$ = Negative Sequence Current

$K1$ = Heating factor of positive sequence current

$K2$ = Heating factor of negative sequence current

There are:

$K1 = 0.5$, $K2 = 6$ for motor in 'cold' condition

$K1 = 1$, $K2 = 6$ for motor in 'hot' condition

A 'hot' condition means that the heat capacity of the motor is increasing, and the motor is approaching tripping. A 'cold' state means

that the heat capacity is close to 0, i.e., the motor has cooled down and is ready to start.

4.4.4.5.2 Thermal Model

The thermal model is as follows:

$$t = \frac{35}{\left(\frac{I_{eq}}{I_{ov}}\right)^2 - 1.05^2} \times T_c$$

Where:

- t = Trip time
- T_c = Heating time constant preset by the user
- I_{ov} = Current setting for thermal protection
- I_{eq} = Equivalent current as described above

Generally, the I_{ov} shall be set as 1.0 to 1.2 multiple of I_e (usually 1.0I_e). And the user shall obtain the motor specification to set the T_c with a proper value.

The user also can quickly use the recommended T_c values based on the Trip class which complied with IEC 60947-4-1.

Example

A motor datasheet declares the Safe Stall Time at 100% Volts with Hot state is 8 seconds, and its Rated Locked Rotor Amps is 7.2I_e.

From the following table, the Trip Class is known as 10 and the recommended T_c value is 6.5.

Trip Time Requirement as per IEC 60947-4-1					Recommended T _c (I _{ov} = 1.0I _e)
Trip Class	Multiple of current setting				
	1.05I _e	1.2I _e	1.5I _e	7.2I _e	
10A	> 2h	< 2h	≤ 2min	2s < T _{trip} ≤ 10s	3.5
10	> 2h	< 2h	≤ 4min	4s < T _{trip} ≤ 10s	6.5
20	> 2h	< 2h	≤ 8min	6s < T _{trip} ≤ 20s	10.0
30	> 2h	< 2h	≤ 12min	9s < T _{trip} ≤ 30s	16.0

**Trip Class – the maximum trip time in seconds under specified conditions of test at 7.2 times the rated current according to IEC 60947-4-1.

Table 4-12 Recommended T_c with Trip Time Requirement by IEC 60974-4-1

The following table is a quick reference guide to the approximate tripping time (in seconds) calculated by the thermal model (providing I₂ = 0, I_{ov} = 1.0I_e, and motor in ‘hot’ condition).

t I/I _{ov}	T _c								
	0.1	0.5	1.0	3.0	5.0	7.0	10.0	16.0	20.0
1.5	3.050	15.251	30.501	91.503	152.505	213.508	305.011	488.017	610.022
2.0	1.208	6.040	12.079	36.238	60.397	84.556	120.794	193.270	241.588
3.0	0.443	2.216	4.432	13.295	22.159	31.022	44.318	70.909	88.636
4.0	0.235	1.175	2.349	7.048	11.747	16.446	23.494	37.590	46.988
5.0	0.146	0.732	1.465	4.394	7.323	10.252	14.646	23.433	29.292
6.0	0.100	0.501	1.003	3.009	5.015	7.021	10.029	16.047	20.059
7.2	0.069	0.345	0.690	2.069	3.449	4.829	6.898	11.037	13.797
8.0	0.056	0.278	0.556	1.669	2.782	3.895	5.565	8.903	11.129
9.0	0.044	0.219	0.438	1.314	2.190	3.066	4.381	7.009	8.761
10.0	0.035	0.177	0.354	1.062	1.770	2.477	3.539	5.662	7.078

Table 4-13 Quick Reference Guide for Tripping Time with Different T_c Settings and Overload Current

4.4.4.5.3 Thermal Pre-Alarm

The relay additionally provides a thermal pre-alarm with a threshold setting for early warning, which may allow the user to correct the problem before a thermal trip occurs.

The pre-alarm threshold can be set as 0 to 99% (typically 90%) of the relay operation level. When the heat capacity of the motor exceeds the pre-alarm threshold, the Alarm LED on the relay will illuminate, indicating that the motor is approaching a thermal overload, and the pre-alarm time delay, after which the thermal protection will trip, will count down on the HMI module.

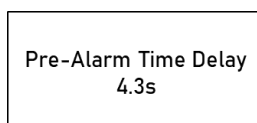

Figure 4-5 Pre-Alarm Time Delay Displayed on Front Panel

4.4.4.5.4 Thermal Dissipation

After relay trips, the motor stops, and the heat capacity decreases until the thermal element has enough available heat capacity to allow the motor to start without tripping. This process is called ‘thermal dissipation’ or ‘cooling’. The relay supports two cooling modes, **Delay** and **Instant**.

In **Delay** mode, set the **Return Threshold** greater than the heat capacity required to start the motor without tripping. In **Instant** mode, the protection returns instantaneously once the maximum current falls below 0.95 times of I_{ov} (current settings for Thermal protection).

During the cooling process, the relay displays the decreasing heat capacity and the countdown **Cooling Time** defined as the waiting time that has to pass until the relay allows reset. (Both Heat Capacity and Cooling Time are displayed as 0 under **Instant** cooling mode).

The following figure illustrates the heat capacity and countdown cooling time at a moment of delayed cooling.

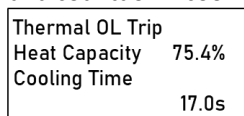

Figure 4-6 Heat Capacity and Cooling Time Displayed on the Front Panel

4.4.4.5.5 Reset Mode

The Reset Mode for Thermal Overload protection output shall be set independently based on the user’s application. There are two modes: **Automatic** and **Manual**. Please refer to **Section 4.4.3** for the descriptions.

4.4.4.5.6 Emergency Start

Where a motor forms part of an essential process, it is sometimes desirable to continue operation, even though the motor is subjected to a temperature above its design limits, and **Emergency Start** is justified for this application.

An emergency start can be initiated through **DI Emergency Start** signal input or the Front Panel’s pushbuttons (set **Control Key** = Emergency). An emergency start signal will cause the Thermal Overload protection to reset, and the DO output contacts defined as Start A or Start B will operate sequentially.

Note that the relay will ignore the emergency start requests if other start inhibitions are not removed.

4.4.4.5.7 Thermal Overload Settings

The following table describes the setting range and default value of the parameters for Thermal Overload protection.

Setting Parameter	Range	Default
Config	OFF, Trip, Alarm, Trip + Alarm	Trip + Alarm
I _{ov}	1.00 to 10.00 (xI _e)	1.00
T _c	0.1 to 99.9	6.5
Cooling	Instant, Delay	Delay
Pre-Alarm Trigger	0 to 100% (0 means thermal pre-alarm disabled)	0
Return Threshold	0 to 100%	60%
Reset Mode	Auto, Manual	Manual
Supplementary Output	R1 <input type="checkbox"/> R2 <input type="checkbox"/> R3 <input type="checkbox"/>	N/A

Table 4-14 Thermal Overload Protection Setting Parameters

4.4.4.6 tE Time Protection

4.4.4.6.1 Overview

This protection applies to the motor of ignition protection type Increased-Safety ‘e’ (suppression of sparks and high temperatures) operating in hazardous locations.

As per **IEC 60079-7: 2015**:

Increased Safety “e” – Type of protection applied to electrical equipment or Ex Components in which additional measures are applied to increase security against the possibility of excessive temperatures and the occurrence of arcs and sparks.

I_A – Highest RMS value of current drawn by an AC motor when at rest or by an AC magnet with its armature clamped in the position of maximum air gap when supplied at rated voltage and a rated frequency.

I_A/I_N – Ratio between initial starting current I_A and rated current I_N.

tE – refers to the time in seconds in the following figure, taken for an AC rotor or stator winding, when carrying the initial starting current I_A , to be heated up to the limiting temperature from the temperature reached in rated service at the maximum ambient temperature.

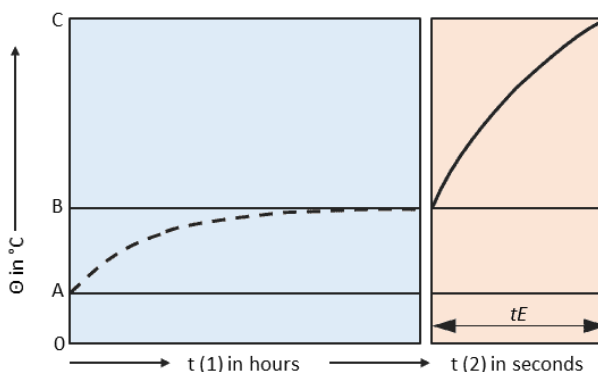

- A – highest permissible ambient temperature
- B – temperature in rated service
- C – limiting temperature
- Θ – temperature
- 1 – temperature rise in rated service
- 2 – temperature during locked rotor test
- t – time

Figure 4-7 Diagram for the Determination of tE Time

The tE protection consists of overcurrent component with inverse time characteristics complied with the following formula:

$$\begin{aligned} \textcircled{1} \quad tE &= \frac{16 \times Tp}{(IA/IN) - 1} && \text{for } 1.2 < IA/IN < 2, \\ \textcircled{2} \quad tE &= \frac{16 \times Tp}{(3 \times IA/IN) - 5} && \text{for } 2 \leq IA/IN \leq 7, \\ \textcircled{3} \quad tE &= Tp && \text{for } IA/IN > 7 \end{aligned}$$

Where Tp is the tE time when the starting current ratio $(IA/IN) = 7$ and is a user-programmable parameter with a setting range of 0.1 to 99.9 seconds. The current-time characteristic of the tE time delay as a function of IA/IN is shown in the following figure. The user shall select an appropriate curve to ensure the motor tripping within the permissible time indicated in the nameplate.

In no case

- a) shall the value of time tE be less than 5 s.
- b) shall the value of the starting current ratio IA/IN exceed 10.

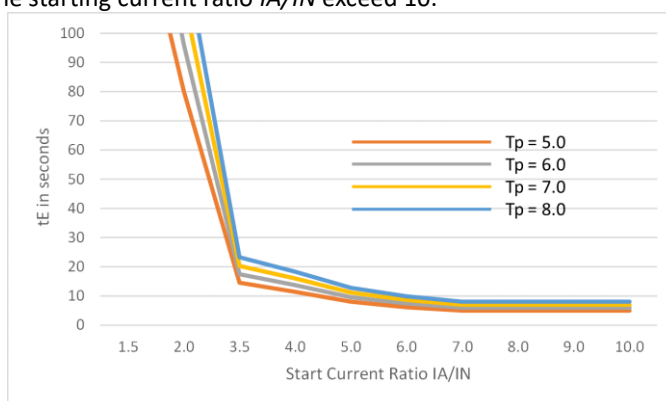

Figure 4-8 Current-Time Characteristics of tE time as a Function of IA/IN

Example

As indicated in the nameplate of the motor below, $IA/IN = 6.1$ and $tE = 30s$. According to **IEC 60079-7: 2015**, the tripping time of the relay should be equal to the tE time $\pm 20\%$. The user shall take the formula $\textcircled{2}$ and the recommended Tp setting would be ~ 19.9 .

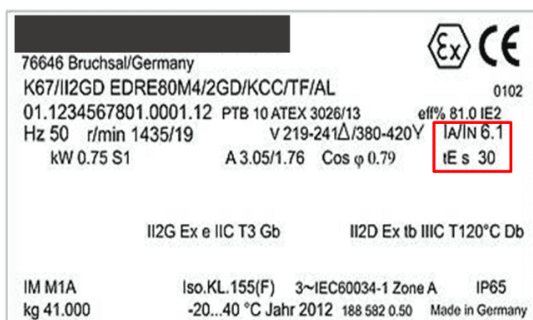

Figure 4-9 An Example for the Nameplate of Increased Safety Motor

4.4.4.6.2 tE Time Settings

The following table describes the setting range and default value of the parameters for tE Time protection.

Setting Parameter	Range	Default
Config	OFF, Trip, Alarm, Trip + Alarm	OFF
Time Delay	0.1 to 99.9 s	6.0 s
Supplementary Output	R1 <input type="checkbox"/> R2 <input type="checkbox"/> R3 <input type="checkbox"/>	N/A

Table 4-15 tE Time Protection Setting Parameters

4.4.4.7 Under Power Protection

4.4.4.7.1 Overview

The relay provides Under Power protection to detect a load loss due to a shaft failure or dry running of the pump. This protection is available only when the motor is running and is disabled when it is starting.

The standard power protection element of the relay calculate the three-phase kW Total based on the following formula using the current and voltage measured.

$$P = U_{ab} \times I_a + U_{bc} \times I_c$$

Notes:

**The Under Power protection is not available if $I_e = 0$ (i.e., the motor is considered having no current flowing across, see Section 4.4.1.3) or LOP detected since the current and voltage are not reached.

** Be careful of the polarity and sequence of the current and voltage, otherwise the Under Power protection may be activated inadvertently.

When the Under Power protection is enabled and the kW Total calculated is less than the programmable threshold for longer than the time delay, the relay issues an alarm and/or trips contactor depending on the output setting.

For Under Power protection, the tripping output could be reset automatically after the specified reset delay once the fault is acknowledged by human intervention.

The following figure illustrates the logic diagram for Under Power protection.

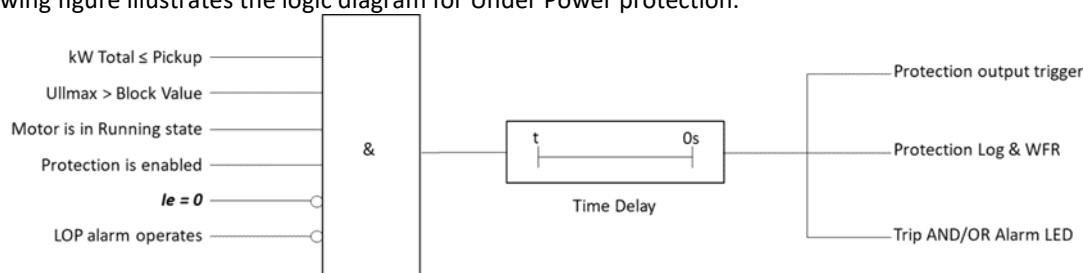

Figure 4-10 Logic Diagram of Under Power Protection

4.4.4.7.2 Under Power Settings

The following table describes the setting range and default values for parameters of Under Power protection.

Setting Parameter	Range	Default
Config	OFF, Trip, Alarm, Trip + Alarm	OFF
Pe	0.1 to 999.9 (kW)	75.0
Pickup	0.10 to 0.95 (xPe)	0.40
Time Delay	0.5 to 99.9 s	5.0 s

Block Value	0.30 to 0.95 (xUe)			0.60
Reset Delay	0.0 to 6000.0 s (0 means disabled)			0
Supplementary Output	R1 <input type="checkbox"/>	R2 <input type="checkbox"/>	R3 <input type="checkbox"/>	N/A

Table 4-16 Under Power Setting Parameters

4.4.4.8 Undervoltage Protection

4.4.4.8.1 Overview

Undervoltage conditions can occur on a power system as a result of increased load or reduced voltage supply. A sustained undervoltage condition will result in motor stalling with a decreased rotor speed. The relay provides the Undervoltage element to take appropriate action to safeguard the motor operation during abnormal or critical situations, for example, load shedding, source change-over and emergency generator starting.

When the Undervoltage protection is enabled, and the phase-to-phase voltage Ullmax is greater than the programmable threshold for longer than the time delay, the relay issues an alarm and/or trips the contactor depending on the output setting. This protection is available only when the motor is running and is disabled when it is starting.

Notes:

**The Undervoltage protection is not available if LOP detected since the voltage are not reached.

Set **No_I Lock to **ON** to block the Undervoltage element if $I_e = 0$ detected (i.e., the motor is considered having no current flowing across, i.e., the motor is going to stop, see **Section 4.4.1.3**).

For Undervoltage protection, the tripping output could be reset automatically after the specified reset delay once the fault is acknowledged by human intervention.

The following figure illustrates the logic diagram for Undervoltage protection.

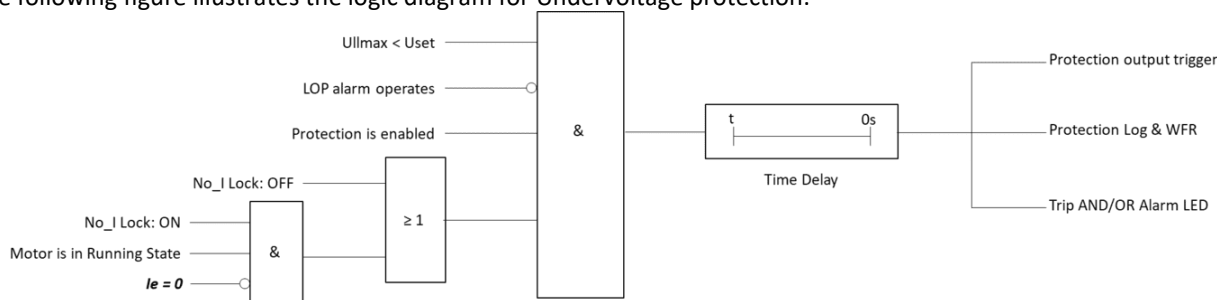

Figure 4-11 Logic Diagram of Undervoltage Protection

4.4.4.8.2 Undervoltage Setting

The following table describes the setting range and default values for the parameters of Undervoltage protection.

Setting Parameter	Range	Default		
Config	OFF, Trip, Alarm, Trip + Alarm	OFF		
Pickup	0.30 to 0.95 (xUe)	0.45		
Time Delay	0.1 to 99.9 s	9.0 s		
No_I Lock	ON, OFF	ON		
Reset Delay	0.0 to 6000.0 s (0 means disabled)	0		
Supplementary Output	R1 <input type="checkbox"/>	R2 <input type="checkbox"/>	R3 <input type="checkbox"/>	N/A

Table 4-17 Undervoltage Protection Setting Parameters

4.4.4.9 Overvoltage Protection

4.4.4.9.1 Overview

Overvoltage may lead to the destruction of the windings due to loss of insulation. The Relay provides the Overvoltage protection available only in motor running state. When the Overvoltage protection is enabled, and the maximum phase-to-phase voltage Ullmax is greater than the programmable threshold for longer than the time delay, the relay issues an alarm and/or trips contactor depending on the output setting.

The following figure illustrates the logic diagram for Overvoltage protection.

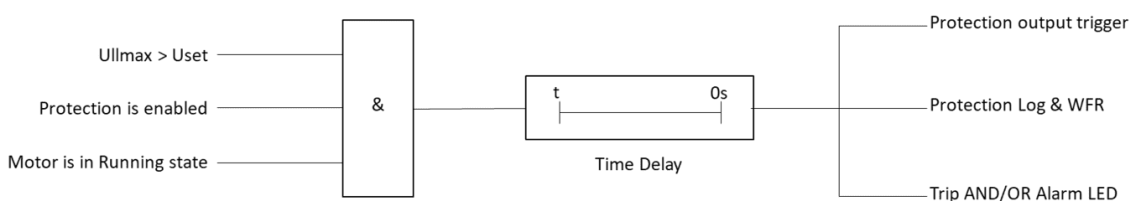

Figure 4-12 Logic Diagram of Overvoltage Protection

4.4.4.9.2 Overvoltage Settings

The following table describes the setting range and default values for the parameters of Overvoltage protection.

Setting Parameter	Range	Default
Config	OFF, Trip, Alarm, Trip + Alarm	OFF
Pickup	1.05 to 1.60 (xUe)	1.20
Time Delay	0.1 to 99.9 s	4.0 s
Supplementary Output	R1 <input type="checkbox"/> R2 <input type="checkbox"/> R3 <input type="checkbox"/>	N/A

Table 4-18 Setting Parameters for Overvoltage Protection

4.4.4.10 Overload Protection

4.4.4.10.1 Overview

The relay provides Overload protection consisting of a definite time overcurrent (DTOC) element as backup protection to be coordinated with other protections. This coordination is based on the fact that the fault current varies with the location of the fault due to the impedance differences between the fault and the source.

When the Overload Protection is enabled and the maximum current is greater than the programmable threshold for longer than the time delay, the relay issues an alarm and/or trips contactor depending on the output setting.

The following figure illustrates the logic diagram for Overload Protection.

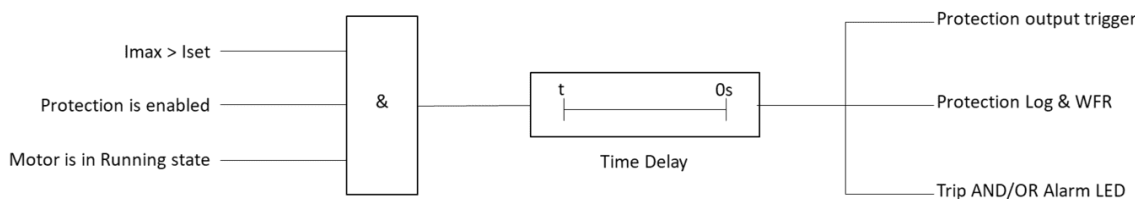

Figure 4-13 Logic Diagram of Overload Protection

4.4.4.10.2 Overload Setting

The following table describes the setting parameters for Overload protection.

Setting Parameter	Range	Default
Config	OFF, Trip, Alarm, Trip + Alarm	OFF
Pickup	0.10 to 1.00 (xIe)	0.40
Time Delay	0.1 to 99.9 s	2.0 s
Supplementary Output	R1 <input type="checkbox"/> R2 <input type="checkbox"/> R3 <input type="checkbox"/>	N/A

Table 4-19 Setting Parameters for Overload Protection

4.4.4.11 Interlock Protection

4.4.4.11.1 Overview

This protection is used to monitor the external control signal. If the Interlock protection is enabled and the **DI Interlock** is active, and the signal persists for longer than the time delay, the relay issues an alarm and/or trips the contactor depending on the output setting (several DIs can be set to **Interlock** simultaneously but as long as one of them is active, the relay will take action to respond to it).

Note

During the power loss Ride-Through period, the Interlock Protection will be blocked (see **Section 0**).

The following figure illustrates the logic diagram for Interlock protection.

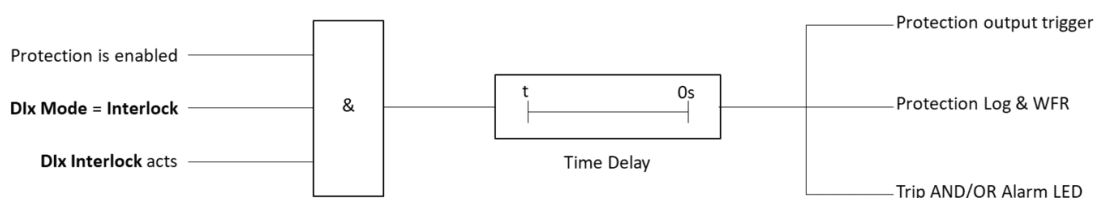

Table 4-20 Interlock Protection Logic Diagram

4.4.4.11.2 Interlock Protection Setting

The following table describes the setting parameters for Interlock protection.

Setting Parameter	Range	Default
Config	OFF, Trip, Alarm, Trip + Alarm	OFF
Time Delay	0.0 to 99.9 s	0.2 s
Supplementary Output	R1 <input type="checkbox"/> R2 <input type="checkbox"/> R3 <input type="checkbox"/>	N/A

Table 4-21 Interlock Protection Setting Parameters

4.4.4.12 Underload Protection

4.4.4.12.1 Overview

For a canned motor or magnetic pump, dry running condition, which happens when pumped fluid flashes, can lead to accelerated wear or shattering by thermal shock. The relay provides an Underload element which is only available when the motor is running and $I_e < 0$ ($I_e \neq 0$) is detected (i.e., the motor is considered to be operational and has a low current flowing across, see section 4.4.1). When the Underload protection is enabled, and the average current I_{avg} is lower than the programmable threshold for longer than the time delay, the relay issues an alarm and/or trips the contactor depending on the output setting.

After the relay trips, the connected DCS (distributed control system) will adjust related configurations to restore good operating conditions. The tripping output could be reset automatically after the specified reset delay once the fault is acknowledged by human intervention.

The following figure illustrates the logic diagram for Underload protection.

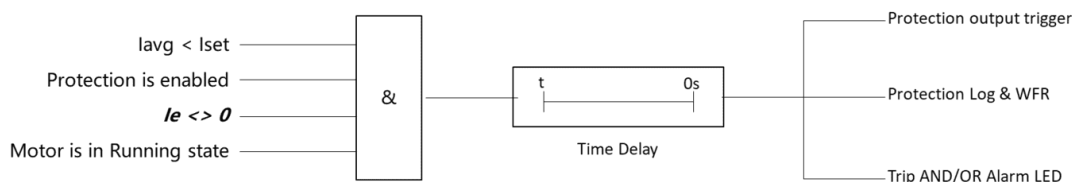

Figure 4-14 Logic Diagram of Underload Protection

4.4.4.12.2 Underload Setting

The following table describes the setting range and default values for the parameters of Underload protection.

Setting Parameter	Range	Default
Config	OFF, Trip, Alarm, Trip + Alarm	OFF
Pickup	0.10 to 1.00 (xI_e)	0.40
Time Delay	1 to 9999 s	20 s
Reset Delay	0.0 to 6000.0 s (0 means disabled)	0
Supplementary Output	R1 <input type="checkbox"/> R2 <input type="checkbox"/> R3 <input type="checkbox"/>	N/A

Table 4-22 Underload protection

4.4.4.13 Circuit Breaker (CB) Failure Protection

4.4.4.13.1 Overview

The relay provides flexible breaker failure logic during the motor start and running stage.

However, if the **DO Start A** or **Start B** output is active during the moto start process, the relay fails to receive the **DI KMA/KMB State** closed status feedback, or if the PMC-MTA is connected and the $I_e = 0$ is detected (i.e., the motor is considered as not operational, see Section 4.4.1.1). The relay judges that the motor can't be started due to a breaker failure.

Another condition is that during the motor running stage, the **DI KMA/KMB State** returns a closed state, and $I_e = 0$ is

detected, although the PMC-MTA is connected. In another word, the motor circuit is open due to breaker failure.

If any of the above fault conditions persist for longer than the time delay, the relay will issue an alarm and/or trip the contactor, depending on the output setting.

Note

During the power loss Ride-Through period, the CB Failure Protection will be blocked (see **Section 0**).

The following figure illustrates the logic diagram for CB Failure protection.

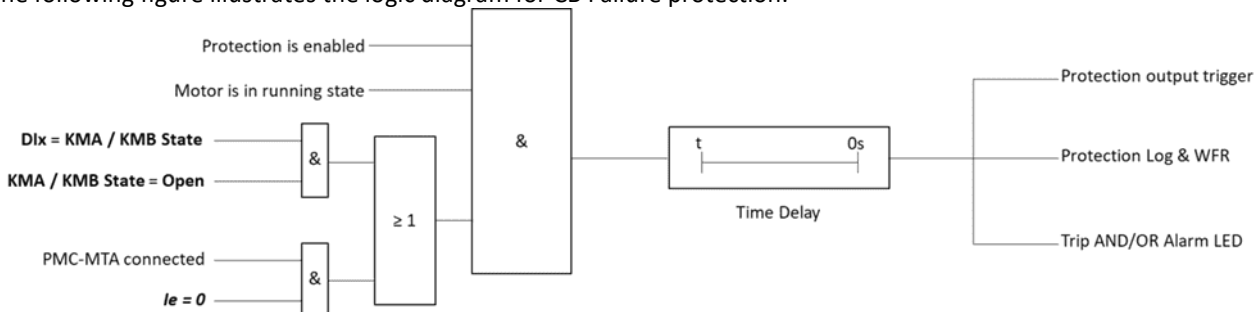

Figure 3-17 Logic Diagram of CB Failure Protection

4.4.4.13.2 CB Failure Setting

The following table describes the setting parameters for CB Failure protection.

Setting Parameter	Range	Default
Config	OFF, Trip, Alarm, Trip + Alarm	OFF
Time Delay	0.1 to 99.9 s	1.0 s
Supplementary Output	R1 R2 R3 <input type="checkbox"/> <input type="checkbox"/> <input type="checkbox"/>	N/A

Table 4-23 CB Failure Protection Setting Parameters

4.4.4.14 Contactor Protection

4.4.4.14.1 Overview

Generally, the Breaking Capacity of the contactor is $6 \cdot I_e$ to $8 \cdot I_e$. When the Contactor protection is enabled and the circuit fault current exceeds the interrupting ratings of the main contactor, the Contactor protection element will energize the shunt trip coil of circuit breaker to clear the fault and prevent the contactor from opening to avoid arcing or melting.

The following figure illustrates the logic diagram for Contactor protection.

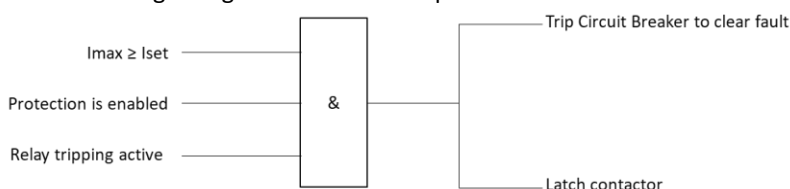

Figure 3-18 Logic Diagram of Contactor Protection

4.4.4.14.2 Contactor Protection Setting

The following table describes the setting range and default values for the parameters of Contactor Protection.

Setting Parameter	Range	Default
Config	ON, OFF	OFF
Pickup (contactor breaking capacity)	4.0 to 20.0 (xIe)	8.0
Supplementary Output	R1 R2 R3 <input type="checkbox"/> <input type="checkbox"/> <input type="checkbox"/>	N/A

Table 4-24 Contactor Protection Setting Parameters

4.4.4.15 Contactor Failure Protection

4.4.4.15.1 Overview

A welded/sticking contactor will fail to disconnect the motor when there is a fault, or a stop command has been received. The relay detects this failure and trips the circuit breaker to break the motor circuit to ensure the equipment's safety.

After the DO trip output has been activated, if the maximum current remains above the programmable threshold, or

the **DI KMA/KMB State** shows a closed state for longer than the time delay, the protection will trip the circuit breaker. Set **Stop Trigger** to **OFF** if the Contactor Failure protection is unexpected when the DO trip output is also used to stop the motor.

Note

During the power loss Ride-Through period, the Contactor Failure protection will be blocked (see **Section 0**).

The following figure illustrates the logic diagram for Contactor Failure protection.

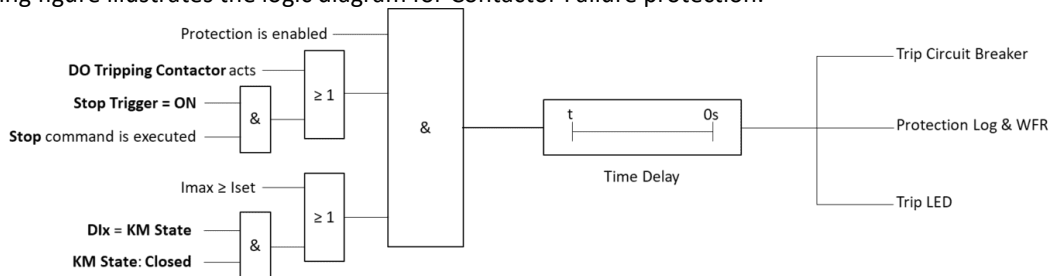

Figure 4-15 Logic Diagram for Contactor Failure Protection

4.4.4.15.2 Contactor Failure Setting

The following table describes the setting parameters for Contactor Failure protection.

Setting Parameter	Range	Default
Config	ON, OFF	OFF
Pickup	0.1 to 5.0 (xIe)	0.3
Time Delay	0.1 to 99.9 s	0.5
Stop Trigger	ON, OFF	ON
Supplementary Output	R1 <input type="checkbox"/> R2 <input type="checkbox"/> R3 <input type="checkbox"/>	N/A

Table 4-25 Setting Parameters for Contactor Failure Protection

4.4.4.16 ACB (Air Circuit Breaker) Control Contactor

4.4.4.16.1 Overview

Usually, the Distributed Control System (DCS) retrieves motor running feedback through the auxiliary contacts of the contactor. When a circuit breaker is working as the tripping output, the DCS will fail to follow up the circuit breaker operation, which may bring trouble to the process. Therefore, the relay provides the ACB Control Contactor element to operate the contactor after the time delay.

Note

During the power loss Ride-Through period, the ACB Control Contactor protection will be blocked (see **Section 0**).

The following figure illustrates the logic diagram for ACB Control Contactor application.

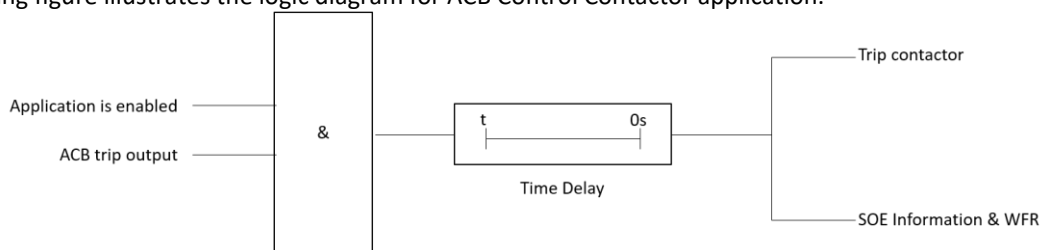

Figure 4-16 ACB Control Contactor Application Logic Diagram

4.4.4.16.2 ACB Control Contactor Setting

The following table illustrates the setting range and default values for the parameters of ACB Control Contactor.

Setting Parameter	Range	Default
Config	ON, OFF	OFF
Time Delay	0.1 to 99.9 s	1.0
Supplementary Output	R1 <input type="checkbox"/> R2 <input type="checkbox"/> R3 <input type="checkbox"/>	N/A

Table 4-26 ACB Control Contactor Application Setting Parameters

4.4.4.17 Emergency Stop Alarm

4.4.4.17.1 Overview

This protection is used to signal an alarm for emergency stop to remind the user. When the Emergency Stop Alarm is enabled and the **DI Emergency Stop** contacts operates, the relay issues an alarm (several DIs can be set to **Emergency Stop** simultaneously but as long as one acts, the relay will take action to respond it).

The following figure illustrates the logic diagram for Emergency Stop Alarm feature.

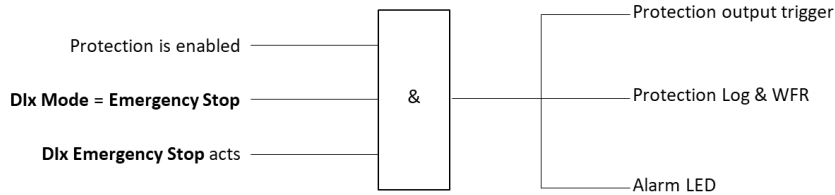

Figure 4-17 Emergency Stop Alarm Logic Diagram

4.4.4.17.2 Emergency Stop Alarm Setting

Setting Parameter	Range	Default
Config	ON, OFF	OFF
Supplementary Output	R1 <input type="checkbox"/> R2 <input type="checkbox"/> R3 <input type="checkbox"/>	N/A

Table 4-27 Emergency Stop Alarm Setting

4.4.5 Electrical Fault Protection and Control

4.4.5.1 Ground Fault Protection

4.4.5.1.1 Overview

A Ground Fault (also called Earth Fault) is an inadvertent connection between the energized conduct and ground, usually occurs when the insulation is broken down due to moisture or vibration.

The Ground Fault protection is carried out with the help of the external sensor, PMC-MIN or based on a relay’s internal Zero Sequence Current calculation from the sum of the phase currents. When Ground Fault protection is enabled and the calculated neutral current (3I0) or measured neutral current (In) exceeds the programmable threshold, Iset for longer than the time delay, the relay issues an alarm and/or trips the contactor depending on the protection output setting.

Considering of the current characteristics, the relay provides two independent time delay settings, **Start Delay** and **Run Delay**, for Ground Fault protection in starting and running processes, respectively. Set a longer start delay to allow the Ground Fault element to ride through the false residual current that can be caused by CT saturation during motor starting.

The relay can provide the following diagnostic indicating where the Ground Fault occurs in the protection log.

- A/B/C Ground Fault
- AB/BC/CA Ground Fault
- ABC Ground Fault

The following figures illustrates the logic diagrams for Ground Fault protection.

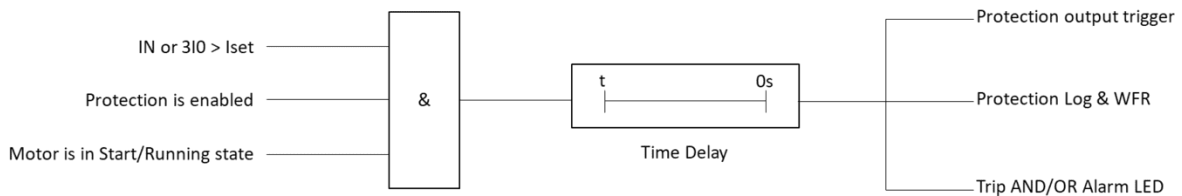

Figure 4-18 Logic Diagram of Ground Fault Protection in Start State

4.4.5.1.2 Ground Fault Settings

The following table describes the setting range and default values for the parameters of Ground Fault protection.

Setting Parameter	Range	Default	
Config	OFF, Trip, Alarm, Trip + Alarm	Trip + Alarm	
Type	IN, 3I0	3I0	
Pickup	0.1 to 10.0 (xIe)	1.0	
Start Delay	0.00 to 99.99 s	0.50 s	
Run Delay	0.0 to 99.9 s	0.1 s	
Supplementary Output	R1 <input type="checkbox"/>	R2 <input type="checkbox"/>	R3 <input type="checkbox"/>
			N/A

Table 4-28 Ground Fault Setting Parameters

4.4.5.2 MTA Failure Alarm

4.4.5.2.1 Overview

The external MTA current transducer is used for measuring the motor phase current. When the MTA Failure Alarm is enabled and the secondary of current transducer is detected disconnected for longer than the time delay, the relay will issue an alarm and the event will be recorded in the protection log.

4.4.5.2.2 MTA Failure Impact on Other Protection Elements

Phase Current Loss and **Imbalance** elements require accurate relaying current for correct operation. It is critical that the relay detects the MTA Failure condition and prevents operation of these elements. For example, if a plug-in connector loose on the PMC-MTA's output, the relay MTA Failure logic accurately determines that this loss of input current is an MTA Failure condition and does not trip. If the current-determined relay elements are used for tripping decisions, please block these elements when the current component is no longer valid (see **Block MTA Failure** in Section 4.4.5.3 and 4.4.5.4).

4.4.5.2.3 MTA Failure Alarm Settings

The following table describes the setting range and default values for the parameters of MTA Failure Alarm.

Setting Parameter	Range	Default	
Config	OFF, ON	OFF	
Time Delay	0.1 to 99.9 s	0.5 s	
Supplementary Output	R1 <input type="checkbox"/>	R2 <input type="checkbox"/>	R3 <input type="checkbox"/>
			N/A

Table 4-29 MTA Failure Alarm Setting Parameters

4.4.5.3 Phase Current Loss Protection

4.4.5.3.1 Overview

The relay provides Phase Current Loss protection based on the current detection. In phase current loss conditions, the motor draws excessive current from the remaining phases, quickly overheating the motor windings.

When the Phase Current Loss protection is enabled and the minimum current, I_{min} is less than the expected motor no-load current ($0.125 \cdot I_e$), but the maximum current I_{max} is greater than the expected motor light-load current ($0.25 \cdot I_e$) for longer than the time delay, the relay issues an alarm and/or trips contactor depending on the output setting.

The relay provides further diagnostic indicating where the Phase Current Loss occurs in the protection log.

- Loss of IA
- Loss of IB
- Loss of IC

The following figure illustrates the logic diagram for Phase Current Loss protection.

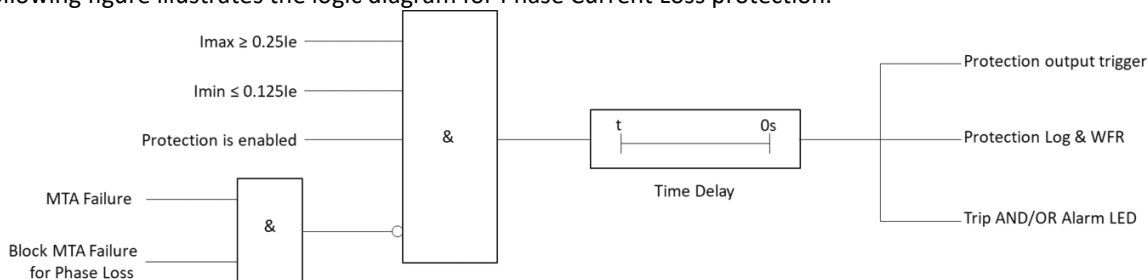

Figure 4-19 Logic Diagram of Phase Current Loss Protection

4.4.5.3.2 Phase Current Loss Settings

The following table describes the setting parameters for Phase Current Loss protection.

Setting Parameter	Range	Default
Config	OFF, Trip, Alarm, Trip + Alarm	Trip + Alarm
Time Delay	0.1 to 99.9 s	2.5 s
Block MTA Failure	Yes, No	No
Supplementary Output	R1 <input type="checkbox"/> R2 <input type="checkbox"/> R3 <input type="checkbox"/>	N/A

Table 4-30 Phase Current Loss Protection Setting Parameters

4.4.5.4 Imbalance Protection

4.4.5.4.1 Overview

Motor stator current imbalance caused by unbalanced terminal voltage will generate an excessive negative sequence component leading to significant rotor heating. The relay provides additional Imbalance protection with current imbalance calculation.

When the Imbalance protection is enabled, and the calculated percent current imbalance exceeds the programmable threshold for longer than the time delay, the relay issues an alarm and/or trips the contactor depending on the output setting. This protection will be disabled if the motor current magnitude doesn't satisfy $I_e < 0$ ($I_e \neq 0$) (i.e., the motor is considered not operating, see **Section 4.4.1**).

The imbalance current is calculated in this way:

$$I_{imbal.} = \frac{\max[(I_{max} - I_{avg}), (I_{avg} - I_{min})]}{I_{avg}} \times 100\%$$

Where

$I_{imbal.}$ = Current imbalance percentage

I_{max} = Max. current of 3 phases

I_{min} = Min. current of 3 phases

I_{av} = Average current of 3 phases

The following figure illustrates the logic diagram for Imbalance protection.

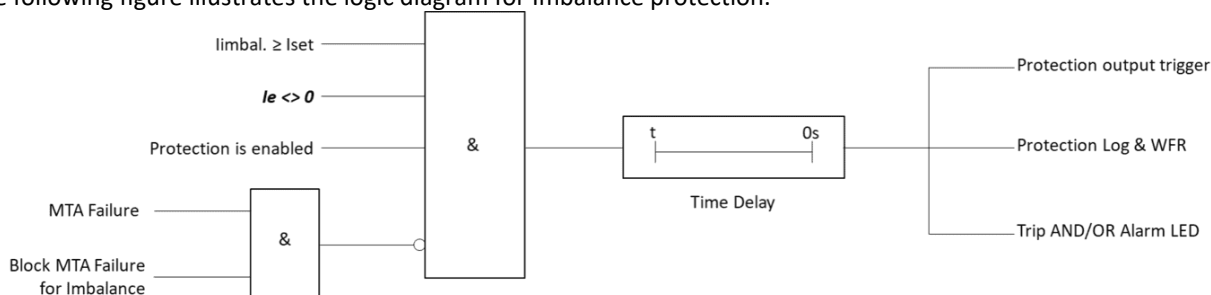

Figure 4-20 Logic Diagram of Imbalance Protection

4.4.5.4.2 Imbalance Settings

The following table describes the setting parameters for Imbalance protection.

Setting Parameter	Range	Default
Config	OFF, Trip, Alarm, Trip + Alarm	Alarm
Pickup	10 to 100 (%)	30
Time Delay	0.1 to 99.9 s	5.0 s
Block Value	0 to 0.80 (xIe)	0.25
Block MTA Failure	Yes, No	No
Supplementary Output	R1 <input type="checkbox"/> R2 <input type="checkbox"/> R3 <input type="checkbox"/>	N/A

Table 4-31 Imbalance Protection Setting Parameters

4.4.5.5 Short Circuit Protection

4.4.5.5.1 Overview

Short Circuit is indicated with an abrupt increasing current, caused by the direct connection between the two points with different electrical potentials.

When the Short Circuit protection is enabled and the maximum current is greater than the programmable threshold for longer than the time delay, the relay issues an alarm and/or trips contactor depending on the output setting.

Use **Start Multiple** to set the sensitivity of the short circuit element from 1.00*pickup to 2.00*pickup in motor start process.

The relay provides the following diagnostics indicating where the Short Circuit fault occurs in the protection log (the ground fault usually is regarded as a typical condition of short circuit fault):

- A/B/C ground fault
- AB/BC/CA ground fault
- ABC ground fault
- AB/BC/CA phase-to-phase short circuit
- ABC short circuit

The following figure illustrates the logic diagram for Short Circuit protection.

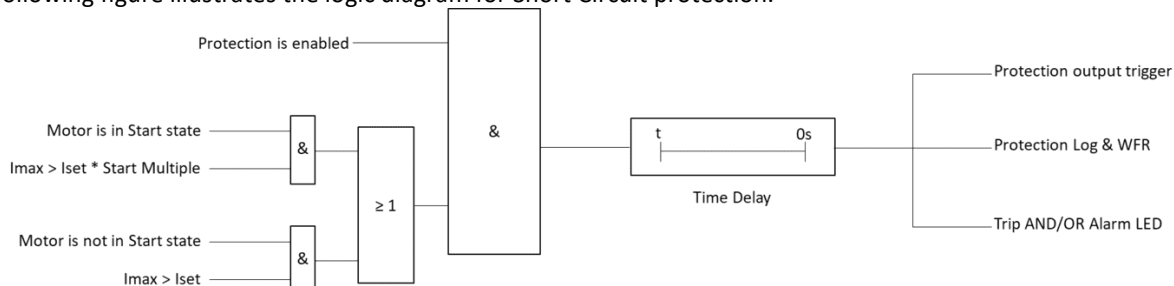

Figure 4-21 Logic Diagram of Short Circuit Protection

4.4.5.5.2 Short Circuit Setting

The following table describes the setting range and default values for the parameters of Short Circuit protection.

Setting Parameter	Range	Default
Config	OFF, Trip, Alarm, Trip + Alarm	Trip + Alarm
Pickup	1.0 to 10.0 (xIe)	7.5
Start Multiple	1.00 to 2.00	1.00
Time Delay	0.1 to 99.9 s	0.0 s
Supplementary Output	R1 <input type="checkbox"/> R2 <input type="checkbox"/> R3 <input type="checkbox"/>	N/A

Table 4-32 Short Circuit Protection Setting Parameters

4.4.5.6 Loss-of-Potential (LOP) Alarm

4.4.5.6.1 Overview

The relay provides the Loss-of-potential (LOP) alarm upon detecting a loss of relay AC voltage input such as that caused by blown potential fuses or by the operation of molded-case circuit breaker (MCCB).

When the LOP alarm is enabled, and the maximum line voltage drops below $0.2 * U_e$, but $I_e < 0$ ($I_e \neq 0$) is detected, see **Section 4.4.1**, or the magnitude difference between any line voltage is larger than $0.2 * U_e$ for longer than 2 seconds, the LOP alarm output operates and the event will be recorded to the protection log and waveform recorder, with the Alarm LED turning on. Once the minimum voltage restores to $0.9 * U_e$, the LOP alarm returns.

The relay provides the following diagnostics indicating where the LOP fault occurs in the protection log:

- Loss of UA/UB/UC
- Loss of UAB/UBC/UCA
- ABC Phase Loss

The following figure illustrates the logic diagram for LOP Alarm.

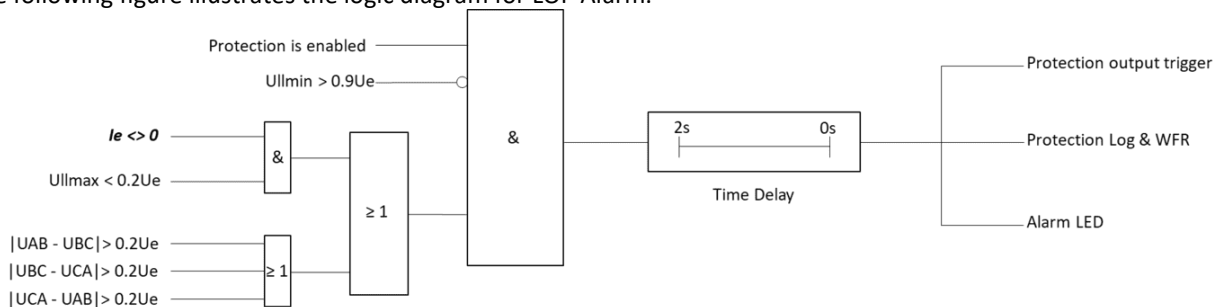

Figure 4-22 Logic Diagram for LOP Alarm

4.4.5.6.2 LOP Alarm Setting

The following table describes the setting range and default values for the parameters of LOP Alarm.

Setting Parameter	Range	Default
Config	OFF, ON	ON
Supplementary Output	R1 <input type="checkbox"/> R2 <input type="checkbox"/> R3 <input type="checkbox"/>	N/A

Table 4-33 LOP Alarm Setting Parameters

4.4.5.7 Phase Reversal Protection

4.4.5.7.1 Overview

The phase reversal affects all the voltage and current measurements in the same way, disregarding which two phases are being swapped.

The relay use phase currents and/or phase voltages to determine that the phase rotation sequence applied to the relay matches the **Current Sequence** and/or **Voltage Sequence** settings. When the Phase Reversal protection is enabled and the incorrect phase sequence is applied for longer than 200ms, the relay issues an alarm and/or trips contactor depending on the output setting.

The relay provides the following diagnostics indicating where the Phase Reversal occurs in the protection log:

- Voltage (U) phase sequence error
- Current (I) phase sequence error
- Voltage and Current phase sequence error

The following figure illustrates the logic diagram for Phase Reversal protection.

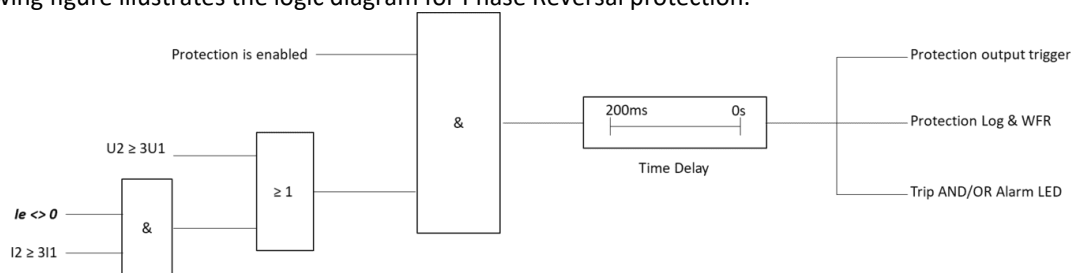

Figure 4-23 Phase Reversal Protection Logic Diagram

Where

U_2 – Voltage negative sequence component, U_1 – Voltage positive sequence component.

I_2 – Current negative sequence component, I_1 – Current positive sequence component.

4.4.5.7.2 Phase Reversal Setting

The following table describes the setting range and default values for the parameters of Phase Reversal protection.

Setting Parameter	Range	Default
Config	OFF, Trip, Alarm, Trip + Alarm	OFF
Supplementary Output	R1 <input type="checkbox"/> R2 <input type="checkbox"/> R3 <input type="checkbox"/>	N/A

Table 4-34 Phase Reversal Parameter Settings

4.4.5.8 Optional Residual Current Protection

4.4.5.8.1 Overview

Residual current protection requires an external transformer, PMC-MIR, through the center of which is passed the three-phase and neutral wires connected to the motor. Residual current protection can detect low-level earth faults with low effective settings.

The relay provides two-level protection for residual current alarm and trip purposes with independent threshold and time delay settings (see **Table 4-35**).

Use **Start Multiple** to set the sensitivity of the residual current element from 1.00*pickup to 2.00*pickup in motor start process.

The following figure illustrates the logic diagram for Residual Current protection.

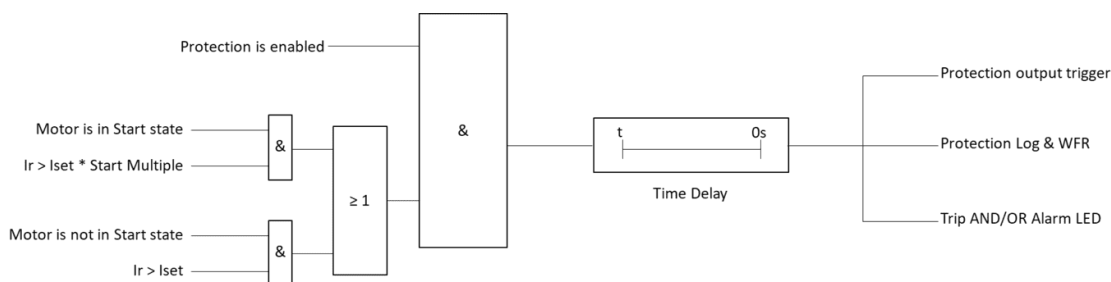

Figure 4-24 Residual Current Protection Logic Diagram

4.4.5.8.2 Residual Current Setting

The following table describes the setting range and default values for the parameters of Residual Current protection.

Setting Parameter	Range	Default
Config	OFF, Trip, Alarm, Trip + Alarm	OFF
Alarm Pickup	20 to 5000 (mA)	300
Alarm Delay	0.0 to 99.9 (s)	5.0
Trip Pickup	20 to 5000 (mA)	500
Trip Delay	0.0 to 99.9 (s)	1.0
Start Multiple	1.00 to 2.00	1.00
Supplementary Output	R1 <input type="checkbox"/> R2 <input type="checkbox"/> R3 <input type="checkbox"/>	N/A

Table 4-35 Residual Current Protection Setting Parameters

4.4.5.9 Negative Sequence Overcurrent Protection

4.4.5.9.1 Overview

The relay offers a Negative Sequence Overcurrent protection to be used in addition to or instead of the current imbalance protection to detect phase-to-phase faults, phase reversal, single phasing and heavy motor imbalance.

False negative sequence current can transiently appear when a circuit breaker or contactor is closed. To avoid tripping for this transient condition, set a longer **Start Delay** for the negative sequence overcurrent element during the motor start.

The following figure illustrates the logic diagram for Negative Sequence Overcurrent protection.

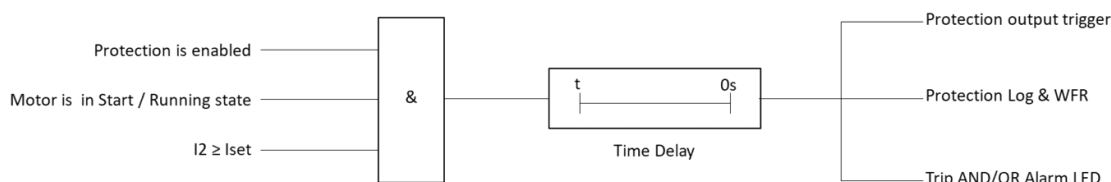

Figure 4-25 Negative Sequence Overcurrent Protection Logic Diagram

4.4.5.9.2 Negative Sequence Overcurrent Setting

The following table describes the setting range and default values for the parameters of Negative Sequence protection.

Setting Parameter	Range	Default
Config	OFF, Trip, Alarm, Trip + Alarm	OFF
Pickup	0.1 to 10.0 (xIe)	1.2
Start Delay	0.0 to 99.9 s	4.0
Run Delay	0.0 to 99.9 s	2.0
Supplementary Output	R1 <input type="checkbox"/> R2 <input type="checkbox"/> R3 <input type="checkbox"/>	N/A

Table 4-36 Negative Sequence Overcurrent Protection Setting Parameters

4.4.5.10 Contactor Abnormal Protection

4.4.5.10.1 Overview

Under different running conditions and starter control (see **Section 2**), the relay detects the contactor abnormal condition via the **DI KMA / KMB State** connected to the auxiliary contacts.

Based on the schematic wiring diagram and DI/DO configurations in **Section 2.13**, when the Contactor Abnormal protection is enabled and the following abnormal condition is detected for longer than the time delay, the relay issues an alarm and/or trips contactor depending on the output setting.

Motor Condition	Abnormal Contactor Condition
Direct-on-line start or running	DI KMA State = Open
Reduce-voltage start (Full-voltage start)	DI KMA State = Open (DI KMB State = Open)
Forward-Reverse or Two-Speed running	DI KMA State = Closed and DI KMB State = Closed simultaneously
Forward or Speed 1 running	DI KMB State = Closed
Reverse or Speed 2 running	DI KMA State = Closed
VFD start (Cooler start)	DI KMA State = Open (DI KMB State = Open)
Large Motor start (Small Motor start)	DI KMA State = Open (DI KMB State = Open)

Table 4-37 Abnormal Contactor Conditions with different Motor Conditions

Note

During the power loss Ride-Through period, the Contactor Abnormal protection will be blocked (see **Section 0**).

The following figure illustrates the logic diagram for Contactor Abnormal protection.

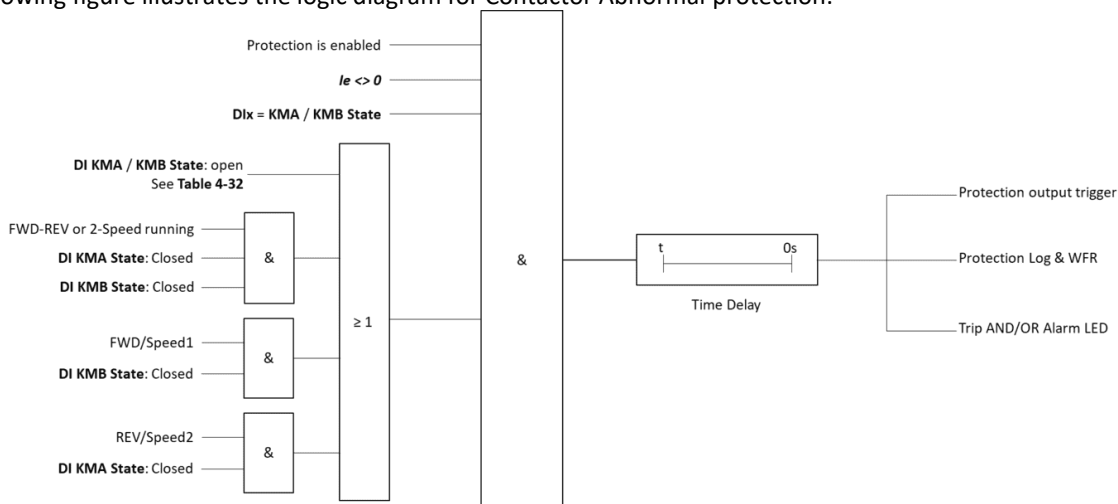

Figure 4-26 Logic Diagram for Contactor Abnormal Protection

4.4.5.10.2 Contactor Abnormal Setting

The following table describes the setting range and default values for the parameters of Contactor Abnormal Protection.

Setting Parameter	Range	Default
Config	OFF, Trip, Alarm, Trip + Alarm	OFF
Time Delay	0.1 to 99.9 s	5.0 s
Supplementary Output	R1 <input type="checkbox"/> R2 <input type="checkbox"/> R3 <input type="checkbox"/>	N/A

Table 4-38 Contactor Abnormal Parameter Settings

4.5 Local/Remote Control Mode

The relay allows manual start/stop the motor in any of the following ways.

- 1) Start A, Start B and Stop control signal inputs via DI
- 2) Start A, Start B and Stop pushbuttons on the Front Panel
- 3) Start A, Start B and Stop register written via Modbus RTU protocol

The relay can either be in Local (e.g., a motor control panel with pushbuttons) or Remote (e.g., DCS or PLC, commands are transferred via cyclic communication telegrams) control mode at any time. The Local/Remote mode can be selected via the DI assigned for **Local/Remote control switch**.

If neither DI is configured as the **Local/Remote** control switch, nor the **DI Local/Remote** is in the **Local** position, the relay can respond to the Local Start / Stop / Forward / Reverse control signals. And if the **DI Local/Remote** control switch is in the **Remote** position, the relay can control the motor based on the Remote Start / Stop / Forward / Reverse control signals. The Local/Remote mode does not affect the Emergency Start / Stop and Forward /Reverse operations.

The user can also use the control buttons on the HMI module to start/stop the motor based on the **Control Key** setting. When the **Control Key** is set to **Disable**, the control buttons are inactive. **Control Key** set to **Emergency** means the button control is always valid regardless of the DI **Local/Remote** value. And under other circumstances, the **Control Key** setting has to be consistent with the **DI Local/Remote** value to make the control buttons active. When neither DI is configured as **Local/Remote**, the **Control Key** has to be set to **Local** so that the control can make sense.

The relay can initiate a start/stop operation remotely via Modbus RTU communications when neither DI is configured

as **Local/Remote** nor the **DI Local/Remote** is in the **Remote** position.

4.6 Undervoltage Restart

To minimize production losses, it is possible to quickly restart the motor after an Undervoltage event or disturbance. This strategy aims to allow the low-voltage motors to restart within the pre-determined time and in a certain order when voltage is restored. These abnormal voltage conditions may be caused by cleared short-circuits upstream, generation and public supply voltage outages, or a simple automatic transfer system (ATS) of selective secondary substation operations.

The relay detects the start of an Undervoltage event when U_{llmax} falls below the **Dip Threshold** and the end when U_{llmin} is equal to or above the **Recover Voltage**. The relay can capture an Undervoltage event with a maximum resolution of 10ms.

Depending on the duration of an Undervoltage event, two possible conditions are considered:

- 1) A short Undervoltage event is also called Dip, < 9.99s. In this condition, the motor can restart immediately without intervention. This scheme is called Quick Start.

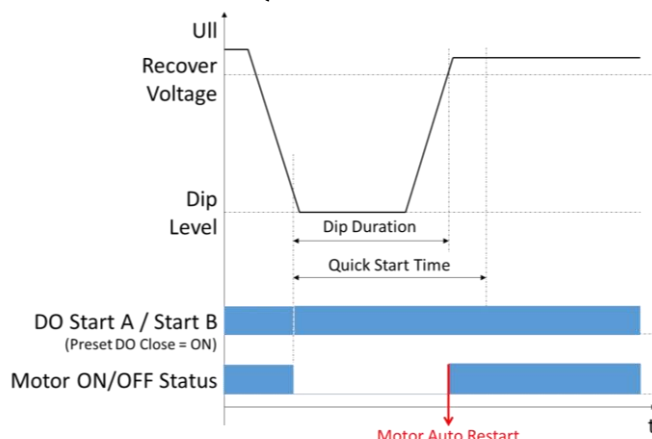
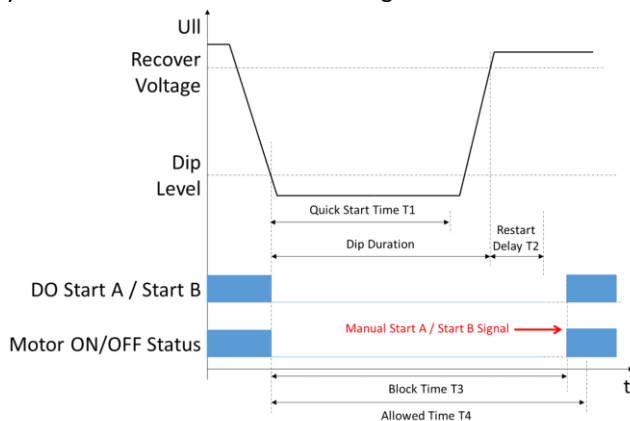

Figure 4-27 Motor Quick Start after the Voltage Dip Event

- 2) A prolonged Undervoltage, < 999.8s. In this condition, the motor can restart with a manual start signal after the preset restart delay. This scheme is called Undervoltage Restart.



$T4 \geq T3 > T1 + T2$,
 During the Block Time $T3$, any manual start request is ignored to maintain the operation of the Undervoltage Restart

Figure 4-28 Motor Undervoltage Restart after the Undervoltage Event

The following table describes the parameters for **Undervoltage Restart** with setting range and default values.

Setting Parameter	Definition	Range, Default*
Dip Threshold	Voltage magnitude, indicating the start of a voltage dip.	0.30 to 0.95 (xUe), 0.45*
Recover Voltage	Voltage magnitude, indicating the end of a voltage dip.	0.80 to 1.60 (xUe), 0.80*
Quick Start		

Quick Start Time	Allowable duration for a short voltage dip. If the voltage recovers within this time, the motor can automatically restart. See Figure 4-27	0 to 9.9 (s), 2.5*
Preset DO Close	ON – Keep the contact of the motor start DO close during the short voltage dip without checking if the voltage has been restored. OFF – The motor start DO will close automatically when the voltage is restored.	ON*, OFF
Pulse Width	When Pulse Width \geq Quick Start Time, the DO configured for the Motor Running indicator will remain closed during the voltage dip event.	0 to 30.00 (s), 0.10*
Undervoltage Restart		
Config	Enable/disable the Undervoltage Restart feature.	ON, OFF*
Restart Delay	Minimum delay in restarting the motor after the voltage is restored. See Figure 4-28.	0.1 to 999.9 (s), 0.2*
Allowed Time	The allowable time for Undervoltage Restart. This time must be longer than the sum of the Quick Start Time and Restart Delay. If the voltage recovers within this time window, the motor can restart with the Undervoltage Restart logic. See Figure 4-28.	0.5 to 999.9 (s), 20.0*
Auxiliary DO	In soft-starter combined control applications, the Auxiliary DO offer a reset signal before restarting the soft-starter if needed.	N/A*, DO1, DO2, DO3, DO4, DO5
Auxiliary DO Delay	Delay in operating the Auxiliary DO after the voltage is restored.	0 to 300.0 (s), 0.0*
Block Time	During the block time, the start request will be blocked by the relay to keep the operation of the Undervoltage Restart. See Figure 4-28.	0 to 99.99 (s), 0*
Pulse Width	When Pulse Width \geq Quick Start t, the DO configured for the motor running indicator will remain closed during a voltage dip	0.00 to 30.00 (s), 0.10*

Table 4-39 Undervoltage Restart Setting Parameters

Notes:

- 1) A zero value of **Quick Start Time** means Quick Start is disabled.
- 2) When the **Auxiliary DO** is used for soft-starter reset signal, the **Auxiliary DO Delay** shall be less than **Restart Delay**.

4.7 Starter Function

Please refer to **Section 2.13** for the Wiring and DI/DO configurations for different Starter functions.

The following table describes the setting parameters for starter function mode with setting range and default value.

PLEASE NOTE THAT MODIFICATION TO ANY STARTER FUNCTION PARAMETERS WILL STOP THE MOTOR.

Setting Parameter	Specifications/Definitions	Range/Default*
Mode	Defines the starter function based on the applications.	Direct-on-line*, Reduce-volt., FWD/REV Start, 2-Speed Start, VFD Start, L-Motor Start
Reduce-Voltage Start (Including Star-Delta Start, Autotransformer Start and Resistance Start)		
Delay	Specify the time delay until which the motor switches to full-voltage running from reduce-voltage start. The switch over from reduce-volt. start to full-volt. running takes place earliest after 1s delay, therefore the delay must be set to at least 1 second.	1.0 to 99.9 (s), 25.0
Iset	Specify the max. allowable current for reduce-voltage start period. If Iset=0, the motor switches to full-volt. running from reduce-voltage start once the Delay time is reached.	0.0 to 3.0 (xle), 0*
Mode	In make-before-break (MBB) mode, DO Start A (reduce-voltage) maintain closed until the DO Start B (full-voltage) operates. While in break-before-make (BBM) mode, DO Start B operate after 1s delay since the DO Start A released. If motor $le < 0$ ($le \neq 0$) is detected after DO Start A released, the relay will alarm that the reduce-voltage start is failed. Please note that make-before-break mode shall NOT be used in Star-Delta start.	MBB, BBM*
FWD/REV Start		
Delay	Specify the minimum time before a start in the opposite direction is possible.	1.0 to 99.9 (s), 5.0*
2-Speed Start		
I1	Nominal current of motor for speed 1.	0.2 to 5.0 (xle), 1.0*
I2	Nominal current of motor for speed 2.	0.2 to 5.0 (xle), 0.5*
Delay	Specify the minimum time before a start at alternative speed is possible.	1.0 to 99.9 (s), 5.0*

VFD Start		
Delay	Specify the minimum time interval between the starts/stops of Cooler and VFD.	1.0 to 99.9 (s), 10.0*
L-Motor Start		
Delay	Specify the minimum time interval between the starts/stops of small motor and large motor.	1.0 to 99.9 (s), 10.0*

Table 4-40 Start Control Mode Setting Parameters

4.8 Communication Test

The relay can verify the data, including **Relay Data, Metering Data, Harmonic, DI Status, DO Status** and **Protection Status**, uploading to the workstation/master via the **Communication Test** feature on the Front Panel.

Once entering a specific sub-menu of Communication Test menu, the data as displayed will be uploaded to the workstation/master for a momentary synchronization. The DI/DO status change or protection operation displayed on Communication Test won't cause any control logic being active while the Trip/Alarm LED indicators will be illuminated. An event for **Communication Test ON** will be generated in SOE at the same time. Exiting the sub-menu means the Communication Test is completed. Another event for **Communication Test OFF** will be recorded in SOE.

Please note that under **Communication Test** mode, the metering and protection functions are not available. Therefore, the **Communication Test** must be only active for commissioning purposes.

4.9 Control Logic Test

During Control Logic Test, it's possible to keep the protective motor running without interruption and simultaneously verify the relay's DI, DO and protection logic.

Function	Descriptions
DI Logic Test	Test the control logic based on the DI settings by simulating the DI operated/released.
DO Logic Test	Test a contactor operation by manually operating/releasing the connected DO.
Protection Logic Test	Test the operation of a protection trigger based on the output settings by simulating the protection activated. The DO Trip and Alarm will be tested if a protection is set to OFF.

Table 4-41 Control Logic Test Descriptions

4.10 Programmable Logic

The relay supports the Programmable Logic (PLC) via CET's PMC-Designer software with Function Block Diagram (FBD) programming language as described in *IEC 61131-3: Programmable controller – Part 3 Programming language*. The function block diagram consists of variable IEC function blocks (including Logic, Arithmetic, Comparison, Timer, etc.) connecting with input and output variables (including Relay Data, Metering Data, DI, DO etc.). The user can also create customized function blocks with self-defined variables via the platforms.

Here is an example.

Create the following FBD with a Timer delay function block, IN1 (DI1) input, DO3-O (DO3 open) output, and ALM_LAMP (Alarm LED) output variables via PMC-Designer and export to the connected PMC-550J. If a FBD is imported successfully to the relay, the symbol  will display on the default screen of Front Panel (see section 3.4.1). When DI1 is closed, after 50ms delay, the DO3 will operate, and the Alarm LED will be light up.

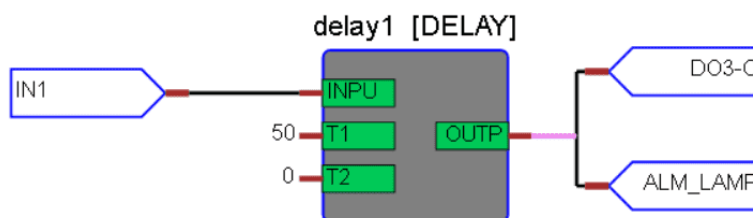

Figure 4-29 An Example for Programmable Logic Diagram

4.11 Metering and Monitoring

4.11.1 Metering

The relay metering data are classified to the following categories.

- Fundamental metering
- RMS metering
- Harmonic metering

4.11.1.1 U/I Metering Threshold

The relay applies a threshold for line voltage and current magnitude metering quantities to force a reading to zero when the measurement is near to zero.

The threshold for current value is 2% * MTA secondary and for line voltage value is 10 * V secondary.

4.11.1.2 Fundamental Metering

The relay provides the following fundamental metering's which are available through the Front Panel or communications.

Relay Options	Metering Parameters
All Models	Line Voltages UAB, UBC, and UCA magnitudes (V) and phase angles (°) Average Line Voltage IA, IB, IC, magnitudes (A) and phase angles (°) Average Current Iavg IA/Ie ratio (%), IB/Ie ratio (%), IC/Ie ratio (%) and Iavg/Ie ratio (%) I1 (positive sequence), I2 (negative sequence) Calculated Neutral Current (3I0) Total kW, Total kvar, Total kVA and PF Current Unbalance (%) Cooling Time (s) and Heat Capacity (%) System Frequency
Models with IN option	Measured Neutral Current (IN)
Models with Ir option	Residual Current Ir

Table 4-42 Fundamental Metering Parameters

4.11.1.3 RMS Metering

The relay provides the following RMS metering at which the motor is running.

Parameters	Phase A	Phase B	Phase C	Total
ULL	●	●	●	--
U Phase Angel	●	●	●	--
I	●	●	●	--
I Phase Angel	●	●	●	--
I/Ie (%)	●	●	●	--
P	--	--	--	●
Q	--	--	--	●
PF	--	--	--	●
kWh Import/Export	--	--	--	●
kvarh Import/Export	--	--	--	●

Table 4-43 RMS Metering Parameters

4.11.1.4 Harmonic Metering

The following table illustrates the voltage and current harmonics measurements on the relay.

Parameters	Phase A	Phase B	Phase C
Voltage / Current Harmonics	THD	THD	THD
	TOHD	TOHD	TOHD
	TEHD	TEHD	TEHD
	2 nd Harmonic	2 nd Harmonic	2 nd Harmonic

	31 st Harmonic	31 st Harmonic	31 st Harmonic

Table 4-44 Harmonic Metering Parameters

4.11.2 Statistic

The relay stores the latest machine operating statistics information for the maintenance of the protected motor in its non-volatile memory. All statistics information will be cleared via Clear Statistics operation on the Front Panel or through communications.

Menu	Parameters	Unit
Statistics	Trip IA, Trip IB and Trip IC (trip current)	A
	Trip Times (total counter for protection trips)	--
	Start I (start current for the last start)	A
	Start Time (for the last start)	s
	Start Counter	--

Total Running Time	h
Running Time (from the last start)	h
Total Stop Time	h
Stop Time (from the last stop)	h
Device Running Time	h
I _r (for the last start)	mA
I _N (for the last start)	A

Table 4-45 Statistics Information

4.11.3 SOE (Sequence of Events)

The relay’s SOE Log can store up to 64 events such as DI/DO Logs, Diagnostic (self-check result) Logs and Maintenance Logs. If there are more than 64 events, the newest event will replace the oldest event on a First-in-First-out basis. All events are stored in the relay’s non-volatile memory. Each event record includes the event classification, its relevant parameter values and a timestamp in 1ms resolution. Please refer to **Appendix A – SOE and Protection Log Classifications** for the details.

All events are available via the Front Panel or through communications. The SOE Log can be reset from the Front Panel or via communications.

4.11.4 Protection Log

The relay’s Protection Log can store up to 64 events such as protection trip/alarm, undervoltage restart fail, invalid start command and so on. If there are more than 64 events, the newest event will replace the oldest event on a First-in-First-out basis. All events are stored in the relay’s non-volatile memory. Each event record includes the event classifications, its relevant parameter values and a timestamp in 1ms resolution. Please refer to **Appendix A – SOE and Protection Log Classifications** for the details.

All events are available via the Front Panel or through communications. The Protection Log can be reset from the Front Panel or via communications.

4.11.5 Start Report

The relay records motor start data for each motor start. The relay can store up to 64 motor start reports in non-volatile memory. The Start Report provides the following information.

- Start control source – Dlx control, Front Panel control, etc. See **Table 4-46**.
- Maximum start current
- Minimum start voltage
- Motor start time
- Timestamp
- Start result – succeeded or failed

The relay calculates the motor start time from the time the start detection criteria is satisfied until the running state is detected (see **Section 4.4.3 Motor States**).

The following table concludes all the motor start control source recorded to Start Report.

1	Dlx control	4	Profibus control	7	Auto-restart	10	Unknown source
2	Front Panel control	5	PLC control	8	External control		
3	Modbus control	6	Under-volt. restart	9	Quick restart		

Table 4-46 Motor Start Control Source

4.11.6 Stop Report

The relay records motor stop data for each motor stop. The relay can store up to 64 motor stop records in non-volatile memory. The Stop Report provides the following information.

- Stop control source – Dlx control, Front Panel control, Modbus control, Profibus control, PLC control, etc.
- IA, IB, IC magnitude
- Timestamp

The following table concludes all the motor stop control source recorded to Stop Report.

1	Dlx control	5	PLC control	9	Control para. update	13	Protection trip
2	Front Panel control	6	Voltage interruption	10	Switch direction	14	Unknown source
3	Modbus control	7	DP control	11	Change speed		
4	Profibus control	8	External control	12	Lock start		

Table 4-47 Motor Stop Control Source

4.12 Self-check

Once connected to power, the relay does a continual internal self-check to verify its hardware status. If any of the faults illustrated in is detected, the relay takes the following actions for correction:

- Alarm LED is illuminated.
- Optional Self-check output will be de-energized.
- The Front Panel displays the latest failure type message automatically.
- Disable protections. The relay disables protection and control elements as well as trip/close logic.

Diagnostic Result	Metering Error
	Fault channel – UAB, UBC, UCA, IA, IB, IC and/or Ir
	Device Parameter Error
	Protection Parameter Error
	Calibration Parameter Error
	Setup Parameter Error
	FRAM Error
FLASH Error	

Table 4-48 Self-Check Diagnostics

The user can access all self-check information via **Log** -> **Diagnostics** menu on the Front Panel or in SOE (see **section 5.8.2**) through Communications.

4.13 Data Recorder

The relay can store up to 10000 entries DR log capable of recording 3-Ø ULL and Current, as well as kW Total. The recorded data is stored in non-volatile memory and will not suffer any loss in the event of a power failure.

The programming of the Data Recorder is supported via the Front Panel or through communications with the following setup parameters:

Parameter	Options/Range, Default*
Record Mode	Full* (Stop-when-full), FIFO (First-in-first-out)
Start Mode	Stop* (disabled), Direct, Logic (triggered by programmable logic)
Record Interval	1 to 600 (s), 60*

Table 4-49 Data Recorder Parameter Setting

The Data Recorder can be triggered by cleaning the Data Recorder when it is full in **Full** (Stop-when-full) mode.

4.14 Wiring Diagnosis

The relay provides wiring error detection and allows the user to check for potential problems, especially during the initial commissioning stage. The user can access the wiring diagnosis result via **Maint.** -> **Diagnosis** menu on the Front Panel. The following wiring errors may be detected:

- Voltage phase reversal
- Current phase reversal
- Incorrect MTA direction

4.15 WFR (Waveform Recorder)

The PMC-550J supports the waveform recording of 3-phase RMS line voltages (ULL), current (I) as well as neutral current (In or 3I0) at a resolution of 2 samples/cycle. The WFR has a fixed length of 850 cycles with pre-fault-cycle of 100. WFR on the PMC-550J can be triggered by protection active, motor start or manually triggered through the Front Panel and communications. The manual trigger command has a higher priority. When a WFR is already in progress, other WFR commands will be ignored until the present recording has completed. The WFR has a capacity of 16 entries organized on a FIFO basis, with the newest WFR log replacing the oldest one. The WFR log is stored in the device's non-volatile memory in COMTRADE file format and will not suffer any loss in the event of power failure.

The WFR log can be downloaded via CET's PMC-EasyConfig or other communications and subsequently viewed using software that supports these industry standard file formats. The following figure shows a waveform recorded for motor

start event.

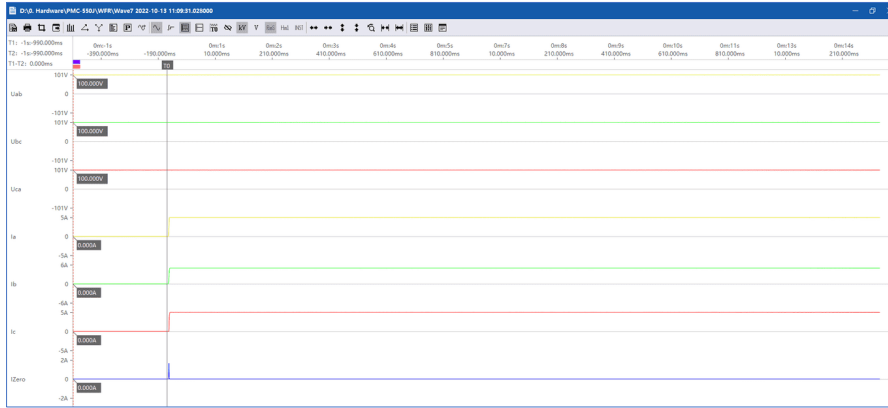

Figure 4-30 Waveform Log for a Motor Start Event

4.16 Enhanced Power Supply

The relay provides an enhanced Power Supply with 30 seconds of Ride-Through for supply interruption.

During the Ride-Through period, the metering, part of the control and protection for the motor will continue to function normally. While the following operations will fail to execute due to power loss.

- Relay's parameters setup
- Energy accumulation
- Front Panel display
- DI Status/Control signal input
- AO output

Chapter 5 Modbus Map

This chapter provides a complete description of the Modbus register map (**Protocol Version 3.4**) for the PMC-550J to facilitate the development of 3rd party Modbus RTU communications driver for accessing information on the relay.

The PMC-550J supports the following Modbus functions:

- 1) Read Holding Registers (Function Code 0x03)
- 2) Force Single Coil (Function Code 0x05)
- 3) Preset Multiple Registers (Function Code 0x10)

For a complete Modbus Protocol Specification, please visit <http://www.modbus.org>.

The following table provides a description of the different data formats used for the Modbus registers. The PMC-550J uses the Big-Endian byte ordering system.

Format	Description
UINT16/INT16	Unsigned/signed 16-bit integer
UINT32/INT32	Unsigned/signed 32-bit integer
INT64	Signed 64-bit integer
FLOAT	IEEE 754 32-bit floating point number (single precision)
BITMAP	16-bit/32-bit binary register where each bit represents a specific quantity
CHAR	16-bit binary register which represents a single Unicode character.

5.1 Real-time Relay Data

Register	Property	Description	Format	Unit	Note
0000	RO	Protection log pointer	UINT32		
0002	RO	SOE log pointer	UINT32		
0004	RO	Start report pointer	UINT16		
0005	RO	Stop report pointer	UINT16		
0006	RO	DR log pointer	UINT32		
0008	RO	WFR log pointer	UINT32		
0010~0014	--	Reserved	--		
0016	RO	DI status	BITMAP		BIT0~BIT7: DI1~DI8, 0=Inactive, 1=Active
0017	RO	DO status	BITMAP		BIT0~BIT4: DO1~DO5, 0=Released, 1=Operated
0018	RO	Protection trip status	UINT16		0=No Trip, 1=Protection Trip
0019	RO	Protection alarm status	UINT16		0=No Alarm, 1=Protection Alarm
0020	RO	Trip source 1 (manual reset)	BITMAP		See Note 1
0021	RO	Trip source 2 (manual reset)	BITMAP		See Note 1
0022	--	Reserved	--		
0023	RO	Alarm source 1 (manual reset)	BITMAP		See Note 2
0024	RO	Alarm source 2 (manual Reset)	BITMAP		See Note 2
0025	--	Reserved	--		
0026	RO	Self-check status	BITMAP		BIT0=Analog/Digital Metering, BIT1=Device Parameter Bit2=Protection Parameter BIT3=Calibration Parameter BIT4=Setup Parameter BIT5=FRAM BIT6=Reserved BIT7=FLASH 0=Normal, 1=Error
0027	RO	Trip source 1 (auto reset)	BITMAP		See Note 1
0028	RO	Trip source 2 (auto reset)	BITMAP		See Note 1
0029	--	Reserved	--		
0030	RO	Alarm source 1 (auto reset)	BITMAP		See Note 2
0031	RO	Alarm source 2 (auto reset)	BITMAP		See Note 2
0032	--	Reserved	--		

0033	RO	Wiring diagnosis	BITMAP		BIT0=Voltage Reversal BIT1=Current Reversal BIT2=IA/IB Switched BIT3=IA/IC Switched BIT4=IB/IC Switched BIT5=MTA Wrong Direction 0=invalid (normal), 1=valid (error)
0034	--	PLC variable status	BITMAP		BIT0~BIT15: VARB1~VARB16, 1=valid
0035	RO	PLC trip (manual reset)	BITMAP		BIT0=PLC Trip 1, BIT1=PLC Trip 2, BIT2=PLC Trip 3, 0=invalid, 1=valid
0036	RO	PLC alarm (manual reset)	BITMAP		BIT0=PLC ALM 1, BIT1=PLC ALM 2, BIT2=PLC ALM 3, 0=invalid, 1=valid
0037	RO	PLC trip ACB (manual reset)	BITMAP		BIT0=PLC Trip ACB 1, BIT1=PLC Trip ACB2. BIT2=PLC Trip ACB 3, 0=invalid, 1=valid
0038	RO	PLC trip (auto reset)	BITMAP		BIT0=PLC Trip 1, BIT1=PLC Trip 2, BIT2=PLC Trip 3, 0=invalid, 1=valid
0039	RO	PLC alarm (auto reset)	BITMAP		BIT0=PLC ALM 1, BIT1=PLC ALM 2, BIT2=PLC ALM 3, 0=invalid, 1=valid
0040	RO	PLC trip ACB (auto reset)	BITMAP		BIT0=PLC Trip ACB 1, BIT1=PLC Trip ACB2. BIT2=PLC Trip ACB 3, 0=invalid, 1=valid
0041~0043	--	Reserved	--		
0044	RO	Fundamental UAB	FLOAT	V	
0046	RO	Fundamental UBC	FLOAT	V	
0048	RO	Fundamental UCA	FLOAT	V	
0050	RO	Fundamental ULL Average	FLOAT	V	
0052	RO	Fundamental IA	FLOAT	A	
0054	RO	Fundamental IB	FLOAT	A	
0056	RO	Fundamental IC	FLOAT	A	
0058	RO	Fundamental I Average	FLOAT	A	
0060	RO	Fundamental I1 (Positive sequence)	FLOAT	A	
0062	RO	Fundamental I2 (Negative sequence)	FLOAT	A	
0064	RO	Fundamental 3I0 (Zero sequence)	FLOAT	A	
0066	RO	Fundamental kW	FLOAT	kW	
0068	RO	Fundamental kvar	FLOAT	kvar	
0070	RO	Fundamental kVA	FLOAT	kVA	
0072	RO	Fundamental PF	FLOAT		
0074	RO	Frequency	FLOAT	Hz	
0076	RO	Fundamental IN	FLOAT	A	
0078	RO	Ir	FLOAT	mA	
0080~0086	--	Reserved	--		
0088	RO	Current imbalance	FLOAT	%	
0090	RO	UAB phase angle	FLOAT	°	
0092	RO	UBC phase angle	FLOAT	°	
0094	RO	UCA phase angle	FLOAT	°	
0096	RO	IA phase angle	FLOAT	°	
0098	RO	IB phase angle	FLOAT	°	
0100	RO	IC phase angle	FLOAT	°	
0102	RO	IA/Ie	FLOAT	%	
0104	RO	IB/Ie	FLOAT	%	
0106	RO	IC/Ie	FLOAT	%	
0108	RO	I Average/Ie	FLOAT	%	
0110	RO	Thermal overload pre-alarm time delay	UINT32	s	x0.1
0112	RO	Thermal overload cooling time	UINT32	s	x0.1
0114	RO	Heat capacity (used)	UINT16	%	x0.1
0115	RO	Motor state	UINT16		0=Stop, 1=Start, 2=Running, 3=Forward, 4=Reverse, 5=Speed 1, 6=Speed2
0116	RO	Equivalent overload protection current	FLOAT	A	

Table 5-1 Real-time Relay Data

Notes:

- The following table illustrates the details for Trip source 1 & 2 (auto/manual reset) with a bit value of “1” meaning protection active.

Source 1							
BIT	Protection	BIT	Protection	BIT	Protection	BIT	Protection
Bit0	Long Start	Bit4	Phase Current Loss	Bit8	Short Circuit	Bit12	Overload
Bit1	Thermal Overload	Bit5	Imbalance	Bit9	Undervoltage	Bit13	Underload
Bit2	Jam	Bit6	Under Power	Bit10	Overvoltage	Bit14	Residual Current
Bit3	Ground Fault	Bit7	Interlock	Bit11	tE Time	Bit15	Reserved
Source 2							
BIT	Protection	BIT	Protection	BIT	Protection	BIT	Protection
Bit0	Phase Reversal	Bit4	Contactora Failure	Bit8	Reserved	Bit12	Reserved
Bit1	Circuit Breaker Failure	Bit5	ACB Control Contactora	Bit9	Reserved	Bit13	Reserved
Bit2	Negative Sequence	Bit6	Reserved	Bit10	Reserved	Bit14	Reserved
Bit3	Contactora Abnormal	Bit7	Reserved	Bit11	Reserved	Bit15	Reserved

Table 5-2 Trip Source 1&2 Details

- The following table illustrates the details for Alarm source 1 & 2 (auto/manual reset) with a bit value of “1” meaning protection active.

Source 1							
BIT	Protection	BIT	Protection	BIT	Protection	BIT	Protection
Bit0	Long Start	Bit4	Phase Current Loss	Bit8	Short Circuit	Bit12	Overload
Bit1	Thermal Overload	Bit5	Imbalance	Bit9	Undervoltage	Bit13	Underload
Bit2	Jam	Bit6	Under Power	Bit10	Overvoltage	Bit14	Reserved
Bit3	Ground Fault	Bit7	Interlock	Bit11	tE Time	Bit15	Residual Current
Source 2							
BIT	Protection	BIT	Protection	BIT	Protection	BIT	Protection
Bit0	Phase Reversal	Bit4	Reserved	Bit8	MTA Failure	Bit12	Reserved
Bit1	Circuit Breaker Failure	Bit5	Reserved	Bit9	Thermal OL Pre-alarm	Bit13	Reserved
Bit2	Negative Sequence	Bit6	LOP	Bit10	Reserved	Bit14	Reserved
Bit3	Contactora Abnormal	Bit7	Emergency Stop	Bit11	Reserved	Bit15	Reserved

Table 5-3 Alarm Source 1 & 2 Details

5.2 Statistic

Register	Property	Description	Format	Unit	Note
0200	RO	Trip IA	UINT32	A	x0.001
0202	RO	Trip IB	UINT32	A	x0.001
0204	RO	Trip IC	UINT32	A	x0.001
0206	RO	Maximum start current	UINT32	A	x0.001
0208	RO	Maximum IN (or 3I0) during start	UINT32	A	x0.001
0210	RO	Maximum Ir during start	UINT16	mA	
0211	RO	Start time (for the last start)	UINT16	s	x0.01
0212	RO	Start counter	UINT16		
0213	RO	Trip times (total counter for protection trips)	UINT16	-	
0214	RO	Total running time	UINT16	h	
0215	RO	Running time (from the last start)	UINT16	h	
0216	RO	Total stop time	UINT16	h	
0217	RO	Stop time (from the last stop)	UINT16	h	
0218	RO	Device running time	UINT32	h	
0220	RO	Start block remaining time	UINT16	s	
0221	RO	Stop block remaining time	UINT16	s	
0222	RO	Max. start counter block remaining time	UINT32	s	

Table 5-4 Statistic Data

5.3 Real-time Metering Data

Register	Property	Description	Format	Unit	Note
0300	RO	Uab	FLOAT	V	
0302	RO	Ubc	FLOAT	V	
0304	RO	Uca	FLOAT	V	
0306	RO	Ull average	FLOAT	V	
0308	RO	Ia	FLOAT	A	
0310	RO	Ib	FLOAT	A	
0312	RO	Ic	FLOAT	A	
0314	RO	I average	FLOAT	A	
0316	RO	P	FLOAT	kW	
0318	RO	Q	FLOAT	kvar	

0320	RO	S	FLOAT	kVA	
0322	RO	PF	FLOAT		
0324	RO	Ia/Ie	FLOAT	%	
0326	RO	Ib/Ie	FLOAT	%	
0328	RO	Ic/Ie	FLOAT	%	
0330	RO	I average/Ie	FLOAT	%	

Table 5-5 Real-time Metering Data

5.4 Energy Measurement

Register	Property	Description	Format	Unit	Note
0500	RW	Total kWh Import	INT32	kWh	x0.01
0502	RW	Total kvarh Import	INT32	kvarh	x0.01
0504	RW	Total kWh Export	INT32	kWh	x0.01
0506	RW	Total kvarh Export	INT32	kvarh	x0.01

Table 5-6 Energy Measurement

5.5 Harmonics Measurement

Register	Property	Description	Format	Unit	Note
0900	RO	I2 Imbalance	FLOAT	%	
0902	RO	Uab THD	FLOAT	%	
0904	RO	Uab TOHD	FLOAT	%	
0906	RO	Uab TEHD	FLOAT	%	
0908	RO	Ubc THD	FLOAT	%	
0910	RO	Ubc TOHD	FLOAT	%	
0912	RO	Ubc TEHD	FLOAT	%	
0914	RO	Uca THD	FLOAT	%	
0916	RO	Uca TOHD	FLOAT	%	
0918	RO	Uca TEHD	FLOAT	%	
0920	RO	Ia THD	FLOAT	%	
0922	RO	Ia TOHD	FLOAT	%	
0924	RO	Ia TEHD	FLOAT	%	
0926	RO	Ib THD	FLOAT	%	
0928	RO	Ib TOHD	FLOAT	%	
0930	RO	Ib TEHD	FLOAT	%	
0932	RO	Ic THD	FLOAT	%	
0934	RO	Ic TOHD	FLOAT	%	
0936	RO	Ic TEHD	FLOAT	%	

Table 5-7 Harmonic Measurement

5.6 Individual Harmonics

Register	Property	Description	Format	Unit	Note
1000	RO	UAB THD	FLOAT	%	
1002	RO	UAB TOHD	FLOAT	%	
1004	RO	UAB TEHD	FLOAT	%	
1006	RO	UAB HD02	FLOAT	%	
1008	RO	UAB HD03	FLOAT	%	
...	RO	...	FLOAT	%	
1064	RO	UAB HD31	FLOAT	%	
1066	RO	UBC THD	FLOAT	%	
1068	RO	UBC TOHD	FLOAT	%	
1070	RO	UBC TEHD	FLOAT	%	
1072	RO	UBC HD02	FLOAT	%	
1074	RO	UBC HD03	FLOAT	%	
...	RO	...	FLOAT	%	
1130	RO	UBC HD31	FLOAT	%	
1132	RO	UCA THD	FLOAT	%	
1134	RO	UCA TOHD	FLOAT	%	
1136	RO	UCA TEHD	FLOAT	%	
1138	RO	UCA HD02	FLOAT	%	
1140	RO	UCA HD03	FLOAT	%	

...	RO	...	FLOAT	%	
1196	RO	UCA HD31	FLOAT	%	
1198	RO	IA THD	FLOAT	%	
1200	RO	IA TOHD	FLOAT	%	
1202	RO	IA TEHD	FLOAT	%	
1204	RO	IA HD02	FLOAT	%	
1206	RO	IA HD03	FLOAT	%	
...	RO	...	FLOAT	%	
1262	RO	IA HD31	FLOAT	%	
1264	RO	IB THD	FLOAT	%	
1266	RO	IB TOHD	FLOAT	%	
1268	RO	IB TEHD	FLOAT	%	
1270	RO	IB HD02	FLOAT	%	
1272	RO	IB HD03	FLOAT	%	
...	RO	...	FLOAT	%	
1328	RO	IB HD31	FLOAT	%	
1330	RO	IC THD	FLOAT	%	
1332	RO	IC TOHD	FLOAT	%	
1334	RO	IC TEHD	FLOAT	%	
1336	RO	IC HD02	FLOAT	%	
1338	RO	IC HD03	FLOAT	%	
...	RO	...	FLOAT	%	
1396	RO	IC HD31	FLOAT	%	

Table 5-8 Individual Harmonics

5.7 Device Setting

5.7.1 System Setting

Register	Property	Description	Format	Range/Options, Default*
41000	RW	Modbus ID	UINT16	1~247, 1*
41001	RW	Modbus baudrate	UINT16	0=1200bps, 1=2400bps, 2=4800bps, 3=9600bps*, 4=19200bps
41002	RW	Modbus data format	UINT16	0=8N2, 1=8O1, 2=8E1*, 3=8N1, 4=8O2, 5=8E2
41003	RW	MTA type ¹	UINT16	1~5000 (A), 100*
41004	RW	Phase TA ratio ²	UINT16	1~5000, 1*
41005	RW	Ie ³	UINT16	1~60000 (x0.1A), 1000*
41006	RW	Primary Ue	UINT16	100~800 (V), 380*
41007	RW	AO parameter	UINT16	0=Ia (A), 1=Ib (A), 2=Ic (A), 3=P (kW), 4=Ir (mA), 5=Io (A)
41008	RW	Zero scale	INT32	-999,999~999,999, 40*
41010	RW	Full scale	INT32	-999,999~999,999, 200*
41012	RW	Control key	UINT16	0=Disabled*, 1=Emergency, 2=Local, 3=Remote
41013	RW	Front panel password	UINT16	0~9999, 0*
41014	--	Reserved	--	
41015	RW	IN TA type	UINT16	0=1A, 1=5A*
41016	RW	IN TA ratio	UINT16	1~1000, 40*
41017	RW	Secondary Ue	UINT16	100~800 (V), 380*
41018	WO	Clear SOE	UINT16	Writing "0xFF00" to the register to execute the described action.
41019	WO	Clear Energy	UINT16	
41020	WO	Clear Statistics	UINT16	
41021	WO	Clear Start Report	UINT16	
41022	WO	Clear Stop Report	UINT16	
41023	WO	Clear Waveform Recorder	UINT16	
41024	WO	Clear Data Recorder	UINT16	
41025~41030	--	Reserved	--	
41031	RW	DO Remote	UINT16	0=OFF*, 1=ON
41032	RW	PROFIBUS DP Control	UINT16	0=OFF*, 1=ON
41033~41034	--	Reserved	--	
41035	RW	DR record mode	UINT16	0=Stop-when-full*, 1=First-in-first-out
41036	RW	DR start mode	UINT16	0=Disabled*, 1=Direct, 2=Logic
41037	RW	DR recording interval	UINT16	1~600 (s), 60*
41038	RW	Ia polarity	UINT16	0=Normal*, 1=Reverse

41039	RW	Ib polarity	UINT16	
41040	RW	Ic polarity	UINT16	
41041	RW	Voltage sequence	UINT16	0=ABC*, 1=CBA
41042	RW	Current sequence	UINT16	0=ABC*, 1=CBA, 2=ACB, 3=CAB, 4=BAC, 5=BCA
41043	RW	Enable PLC	UINT16	0=No, 1=Yes*
41044	RW	MTA connected	UINT16	0=No, 1=Yes*
41045	RW	Start hold time	UINT16	5~9999 (x0.01s), 200*
41046	RW	Starting current threshold	UINT16	100~800 (x0.01Ie), 110*
41047	RW	Starting current return threshold	UINT16	30~200 (x0.01Ie), 110*
41048	RW	Language	UINT16	0=Chinese, 1=English*
41049	RW	ROFIBUS DP control delay	UINT16	1~9999 (x0.1s), 50*
41050	RW	ROFIBUS DP communication ID	UINT16	1~125, 1*
41051	RW	ROFIBUS DP communication baudrate	UINT16	0=9.6kbps, 1=19.2kbps, 2=45.45kbps, 3=93.75kbps, 4=187.5kbps, 5=500kbps, 6=1500kbps*
41052	RW	Undervoltage restart motor running pulse width	UINT16	10~9999 (x0.01s), 20*
41053	RW	Voltage-loss interlock DI scanning	UINT16	0=Disabled, 1=Enabled*
41054	RW	Run LED Indicator	UINT16	0=Device running status*, 1=Motor running status

Table 5-9 System Setting

Notes:

- The following table illustrates the recommended PMC-MTA type based on the rated Current and Power.

MTA Type	Rated kW	Rated Current
PMC-MTA-1A	< 0.4 kW	0.2 - 1 A
PMC-MTA-5A	0.4 - 2.2 kW	1 - 5 A
PMC-MTA-25A	2.2 - 12.5 kW	5 - 25 A
PMC-MTA-100A	12.5 - 50 kW	25 - 100 A
PMC-MTA-300A	50 - 150 kW	100 - 300 A
PMC-MTA-400A-T	120 - 200 kW	240 - 400 A
PMC-MTA-800A-T	160 - 400 kW	320 - 800 A

Table 5-10 Recommended PMC-MTA Type

- In some applications, it is required to use an additional protection current transformer (TA) to transform the circuit current to the relay's PMC-MTA Input. And the **Phase TA Ratio** should be set based on the Primary and Secondary of the protection current transformer. For example, to protect a LV motor rated at 500kW, 1200A, the Primary Input and Secondary Output of the used protection current transformer can be 1200A, 5A, respectively. The **Phase TA Ratio** should be set as $(1200A/5A) = 240$. Please note that **MTA Type x Phase TA Ratio** ≤ 5000.
- The following table illustrates that the motor rated Current Ie has a setting range based on **Z = MTA Type x Phase TA Ratio**.

Z	Ie Setting Range
< 100	0.1 – 1.2 (*Z)
≥ 100	0.2 – 1.2 (*Z)

Table 5-11 Motor Rated Current Ie Setting Range

5.7.2 Protection and Control Setting

Register	Property	Description	Format	Range/Options, Default*
41200	RW	Trip reset mode	UINT16	0= Auto, 1=Manual*
41201	RW	Alarm reset mode	UINT16	0= Auto*, 1=Manual
41202	RW	Enable Restart after Voltage Dip	BITMAP	See Note 1, 0*
41203	RW	Enable protection trip	BITMAP	See Note 2, 0x0000 0282* (Thermal Overload, Ground Fault, Phase Current Loss, Short Circuit)
41205	RW	Enable protection alarm	BITMAP	See Note 3, 0x1681 0298* (Thermal Overload, Ground Fault, Phase Current Loss, Imbalance, Short Circuit, LOP, Emergency Stop)
41207	RW	Short Circuit pickup	UINT16	10~100 (x0.1Ie), 75*
41208	RW	Short Circuit delay	UINT16	0~999 (x0.1s), 0*
41209	RW	Jam protection pickup	UINT16	10~100 (x0.1Ie), 35*
41210	RW	Jam protection delay	UINT16	1~999 (x0.1s), 40*
41211	RW	Overload pickup	UINT16	10~100 (x0.1Ie), 12*
41212	RW	Overload delay	UINT16	1~999 (x0.1s), 300*
41213	RW	Thermal Overload Iov ⁴	UINT16	100~1000 (x0.01Ie), 100*
41214	RW	Thermal Overload Tc ⁴	UINT16	1~999 (x0.1s), 65*

41215	RW	Thermal Overload cooling method ⁵	UINT16	0=Instant, 1=Delay*
41216	RW	Ground Fault IN/IO pickup	UINT16	1~100 (x0.1Ie), 10*
41217	RW	Ground Fault run delay	UINT16	0~999 (x0.1s), 1*
41218	RW	Imbalance protection pickup	UINT16	10~100 (%), 30*
41219	RW	Imbalance protection delay	UINT16	1~999 (x0.1s), 50*
41220	RW	Phase Current Loss protection delay	UINT16	1~999 (x0.1s), 25*
41221	RW	Undervoltage protection pickup	UINT16	30~95 (x0.01Ue), 45*
41222	RW	Undervoltage protection delay	UINT16	1~999 (x0.1s), 90*
41223	RW	Undervoltage No_I Lock	UINT16	0=Disabled, 1=Enabled*
41224	RW	Overvoltage protection pickup	UINT16	105~160 (x0.01Ue), 120*
41225	RW	Overvoltage protection delay	UINT16	1~999 (x0.1s), 40*
41226	RW	tE protection Tp ⁶	UINT16	1~999 (x0.1s), 60*
41227	RW	Long Start protection delay	UINT16	1~999 (x0.1s), 300*
41228	RW	Interlock protection delay	UINT16	0~999 (x0.1s), 2*
41229	RW	Under Power protection Pe	UINT16	1~9999 (x0.1kW), 750*
41230	RW	Under Power protection pickup	UINT16	10~95 (x0.01Pe), 40*
41231	RW	Under Power protection delay	UINT16	5~999 (x0.1s), 50*
41232	RW	Underload protection pickup	UINT16	10~100 (x0.01Ie), 40*
41233	RW	Underload protection delay	UINT16	1~9999 (x0.1s), 20*
41234	RW	Residual Current protection alarm pickup	UINT16	20~5000 mA, 300*
41235	RW	Residual Current protection trip pickup	UINT16	20~5000 mA, 500*
41236	RW	Residual Current protection alarm delay	UINT16	0~999 (x0.1s), 50*
41237	RW	Residual Current protection trip delay	UINT16	0~999 (x0.1s), 10*
41238	RW	Contactors protection pickup (breaking capacity)	UINT16	40~200 (x0.1Ie), 80*
41239	RW	Quick Start Time (for a short voltage dip) ⁷	UINT16	0~99 (x0.1s), 25* (0 means disabled)
41240	RW	Allowed Time (for a longer voltage dip) ⁷	UINT16	5~9999 (x0.1s), 200*
41241	RW	Undervoltage restart delay ⁷	UINT16	1~9999 (x0.1s), 2*
41242	RW	Dip Threshold	UINT16	30~95 (x0.01Ue), 45*
41243	RW	Recover Voltage	UINT16	80~160 (x0.01Ue), 80*
41244	RW	Auto-restart mode (after a long voltage dip)	UINT16	0=Restart, 1=Recover*
41245	RW	Auto-restart delay	UINT16	1~999 (x0.1s), 1*
41246	RW	Reduce-Voltage start delay	UINT16	10~999 (x0.1s), 250*
41247	RW	Reduce-Voltage start mode	UINT16	0=BBM (break-before-make) *, 1=MBB (make-before-break)
41248	RW	2-Speed start I1 (Inominal for speed 1)	UINT16	2~50 (x0.1Ie), 10*
41249	RW	2-Speed start I2 (Inominal for speed 2)	UINT16	2~50 (x0.1Ie), 5*
41250	RW	VFD start delay	UINT16	10~999 (x0.1s), 100*
41251	RW	L-Motor start delay	UINT16	10~999 (x0.1s), 100*
41252	--	Reserved	--	
41253	RW	R1 trigger source	BITMAP	See Note 8, 0*
41255	RW	R2 trigger source	BITMAP	
41257	RW	R3 trigger source	BITMAP	
41259~41261	--	Reserved	--	
41262	RW	Short Circuit start multiple	UINT16	100~200 (x0.01), 100*
41263~41266	--	Reserved	--	
41267	RW	Circuit Breaker Failure protection delay	UINT16	1~999 (x0.1s), 10*
41268	RW	Undervoltage Restart auxiliary DO	UINT16	0=N/A*, 1~5: DO1~DO5
41269	RW	Undervoltage Restart auxiliary DO delay	UINT16	0~3000 (x0.1s), 0*

41270	--	Reserved	--	
41271	--	Reserved	--	
41272	RW	Step-down starting switching current	UINT16	0~30 (x0.1Ie), 0* (0 means disabled)
41273	RW	Thermal pre-alarm threshold	UINT16	0~99 (%), 0* (0 means disabled)
41274	RW	Residual Current protection start multiple	UINT16	100~200 (x0.01), 100*
41275	RW	Thermal Overload return threshold ⁹	UINT16	0~100 (%), 60* (0 means disabled)
41276	RW	Thermal Overload reset mode	UINT16	0=Auto, 1=Manual*
41277	RW	Ground Fault Type	UINT16	0=3I0* (Calculated), 1=IN (Measured)
41278	RW	Block protection time (when motor start)	UINT16	0~999 (x0.1), 100* (0 means disabled)
41279	RW	Block when start	BITMAP	See Note 10, 0*
41281	RW	Start Control - Start Block Time	UINT16	0~9999 (s), 0* (0 means disabled)
41282	RW	Start Control - Stop Block Time	UINT16	0~9999 (s), 0* (0 means disabled)
41283	RW	Start Control - Max. Start Count	UINT16	0~20, 0* (0 means disabled)
41284	RW	Start Control - Interval	UINT16	1~9999 (min), 30*
41285	RW	DO Motor Running pulse width	UINT16	0~3000 (x0.01s), 10*
41286	RW	Ground Fault start delay	UINT16	0~9999 (x0.01s), 50*
41287	RW	Undervoltage Restart Preset DO Close	UINT16	0=OFF, 1=ON*
41288	RW	Stop Trigger for Contactor Failure protection	UINT16	0=OFF, 1=ON*
41289	RW	Contactor Failure protection pickup	UINT16	1~50 (x0.1Ie), 3*
41290	RW	Contactor Failure protection delay	UINT16	1~999 (x0.1s), 5*
41291	RW	ACB Trip Contactor	UINT16	0=OFF*, 1=ON
41292	RW	ACB Trip Contactor delay	UINT16	1~999 (x0.1s), 10*
41293	RW	Under Power protection reset delay	UINT16	0~60000 (x0.1s), 0* (0 means disabled)
41294	RW	Underload protection reset delay	UINT16	0~60000 (x0.1s), 0* (0 means disabled)
41295	RW	Undervoltage protection reset delay	UINT16	0~60000 (x0.1s), 0* (0 means disabled)
41296	--	Reserved	--	
41297	RW	MTA Failure Alarm delay	UINT16	1~999 (x0.1s), 5*
41298	RW	Phase Current Loss block MTA failure	UINT16	0=No*, 1=Yes
41299	RW	Imbalance protection block MTA failure	UINT16	0=No*, 1=Yes
41300	RW	2-Speed start minimum delay	UINT16	10~999 (x0.1s), 50*
41301	RW	Forward-reverse start minimum delay	UINT16	10~999 (x0.1s), 50*
41302	RW	Start Control mode	UINT16	0=Direct-on-line*, 1=Reduce-volt., 2=FWD-REV, 3=2-Speed, 4=VFD Start, 5=L-Motor Start
41303	RW	Undervoltage Ue for blocking Under Power protection	UINT16	30~95 (x0.01Ue), 60*
41304	RW	Contactor Abnormal protection delay	UINT16	10~999 (x0.1s), 50*
41305	RW	Stop DI Trigger Trip Output Mode	UINT16	0=Latched*, 1=Pulse
41306	RW	Imbalance Ie for blocking current imbalance protection	UINT16	0 (disabled)~80 (x0.01Ie), 25*
41307	RW	Negative Sequence protection pickup	UINT16	1~100 (x0.1Ie), 12*
41308	RW	Negative Sequence protection operation delay	UINT16	0~999 (x0.1s), 20*
41309	RW	Negative Sequence protection start delay	UINT16	0~999 (x0.1s), 40*

Table 5-12 Protection and Control Setting

Notes:

1. The Bit0 and Bit1 of **Enable Restart after Voltage Dip** register (41202) represents Undervoltage Restart and Auto-Restart, respectively, with a bit

value of “1” meaning enabled and “0” meaning disabled.

- The following table illustrates the details for **Enable protection trip** register (41203~41204), with a bit value of “1” meaning enabled and “0” meaning disabled.

BIT	Protection	BIT	Protection	BIT	Protection	BIT	Protection
Bit0	Long Start	Bit8	Short Circuit	Bit16	Contactors protection	Bit24	Reserved
Bit1	Thermal Overload	Bit9	Undervoltage	Bit17	Contactors Abnormal	Bit25	Reserved
Bit2	Jam	Bit10	Overvoltage	Bit18	Circuit Breaker Failure	Bit26	Contactors Failure
Bit3	Ground Fault	Bit11	tE Time	Bit19	Negative Sequence	Bit27	Reserved
Bit4	Phase Current Loss	Bit12	Overload	Bit20	Reserved	Bit28	Reserved
Bit5	Imbalance	Bit13	Underload	Bit21	Reserved	Bit29	Reserved
Bit6	Under Power	Bit14	Residual Current	Bit22	Reserved	Bit30	Reserved
Bit7	Interlock	Bit15	Phase Reversal	Bit23	Reserved	Bit31	Reserved

Table 5-13 Enable protection trip register detail

- The following table illustrates the details for **Enable protection alarm** register (41205~41206), with a bit value of “1” meaning enabled and “0” meaning disabled.

BIT	Protection	BIT	Protection	BIT	Protection	BIT	Protection
Bit0	Long Start	Bit8	Short Circuit	Bit16	Phase Reversal	Bit24	Emergency Stop
Bit1	Thermal Overload	Bit9	Undervoltage	Bit17	Contactors Abnormal	Bit25	Reserved
Bit2	Jam	Bit10	Overvoltage	Bit18	Circuit Breaker Failure	Bit26	Reserved
Bit3	Ground Fault	Bit11	tE Time	Bit19	Negative Sequence	Bit27	MTA Failure
Bit4	Phase Current Loss	Bit12	Overload	Bit20	Reserved	Bit28	Reserved
Bit5	Imbalance	Bit13	Underload	Bit21	Reserved	Bit29	Reserved
Bit6	Under Power	Bit14	Residual Current	Bit22	Reserved	Bit30	Reserved
Bit7	Interlock	Bit15	LOP	Bit23	Reserved	Bit31	Reserved

Table 5-14 Enable protection alarm register detail

- Please refer to **Section 0** to set a proper Tc and Iov for the Thermal Model based on the motor nameplate information.
- In **Delay** mode, the estimate time for motor restart is 4Tp (Tp stands for the trip time when the motor is started with a starting current of 7.2Ie). And in **Instant** mode, the Thermal Overload protection returns once the maximum current falls below 0.95*Iov.
- Please refer to **Section 4.4.4.6** to set a proper Tp value for tE Time protection based on the motor nameplate information.
- The **Allowed Time** shall be longer than the accumulation of **Quick Start Time** and **Auto-Restart Delay**.
- The following table illustrates the details for trigger source of R1/R2/R3 supplementary output, with a bit value of “1” meaning the supplementary output will operate when the specific protection trip/alarm active.

BIT	Protection	BIT	Protection	BIT	Protection	BIT	Protection
Bit0	Long Start	Bit8	Short Circuit	Bit16	LOP	Bit24	Emergency Stop
Bit1	Thermal Overload	Bit9	Undervoltage	Bit17	Contactors Abnormal	Bit25	Reserved
Bit2	Jam	Bit10	Overvoltage	Bit18	Circuit Breaker Failure	Bit26	Reserved
Bit3	Ground Fault	Bit11	tE Time	Bit19	Negative Sequence	Bit27	MTA Failure
Bit4	Phase Current Loss	Bit12	Overload	Bit20	Reserved	Bit28	Reserved
Bit5	Imbalance	Bit13	Underload	Bit21	Reserved	Bit29	Reserved
Bit6	Under Power	Bit14	Residual Current	Bit22	Reserved	Bit30	Reserved
Bit7	Interlock	Bit15	Phase Reversal	Bit23	Reserved	Bit31	Reserved

Table 5-15 R1/R2/R3 Trigger Source

- The **Thermal Overload return threshold** is valid only when **Thermal Overload cooling method** (register **41215**) is set to **Delay**.
- The following table illustrates all the protection options for Block When Start with a bit value of “1” meaning Block and “0” meaning Unblock.

BIT	Protection	BIT	Protection	BIT	Protection	BIT	Protection
Bit0	Thermal Overload	Bit4	Imbalance	Bit8	Residual Current	Bit12	Phase Reversal
Bit1	Jam	Bit5	Under Power	Bit9	Overload	Bit13	Negative Sequence
Bit2	Ground Fault	Bit6	Interlock	Bit10	Underload	Bit14~Bit31	Reserved
Bit3	Phase Current Loss	Bit7	Short Circuit	Bit11	tE Time		

Table 5-16 Protection options for Block When Start

5.7.3 DI Setting

Register	Property	Description	Format	Range/Options, Default*
41400	RW	DI1 Mode	UINT16	0~23 (See Note 1), 0* (Common state)
41401	RW	DI1 Type	UINT16	0=NO* (Normally Open), 1=NC (Normally Closed)
41402	RW	DI1 Debounce Time	UINT16	20~9999 (ms), 40*
41403	RW	DI1 Excitation Source	UINT16	0=DC*, 1=AC, 2=External
41404	RW	DI2 Mode	UINT16	0~23 (See Note 1), 0* (Common state)
41405	RW	DI2 Type	UINT16	0=NO* (Normally Open), 1=NC (Normally Closed)
41406	RW	DI2 Debounce Time	UINT16	20~9999 (ms), 40*
41407	RW	DI2 Excitation Source	UINT16	0=DC*, 1=AC, 2=External
41408	RW	DI3 Mode	UINT16	0~23 (See Note 1), 0* (Common state)
41409	RW	DI3 Type	UINT16	0=NO* (Normally Open), 1=NC (Normally Closed)
41410	RW	DI3 Debounce Time	UINT16	20~9999 (ms), 40*
41411	RW	DI3 Excitation Source	UINT16	0=DC*, 1=AC, 2=External

41412	RW	DI4 Mode	UINT16	0~23 (See Note 1), 0* (Common state)
41413	RW	DI4 Type	UINT16	0=NO* (Normally Open), 1=NC (Normally Closed)
41414	RW	DI4 Debounce Time	UINT16	20~9999 (ms), 40*
41415	RW	DI4 Excitation Source	UINT16	0=DC*, 1=AC, 2=External
41416	RW	DI5 Mode	UINT16	0~23 (See Note 1), 0* (Common State)
41417	RW	DI5 Type	UINT16	0=NO* (Normally Open), 1=NC (Normally Closed)
41418	RW	DI5 Debounce Time	UINT16	20~9999 (ms), 40*
41419	RW	DI5 Excitation Source	UINT16	0=DC*, 1=AC, 2=External
41420	RW	DI6 Mode	UINT16	0~23 (See Note 1), 0* (Common state)
41421	RW	DI6 Type	UINT16	0=NO* (Normally Open), 1=NC (Normally Closed)
41422	RW	DI6 Debounce Time	UINT16	20~9999 (ms), 40*
41423	RW	DI6 Excitation Source	UINT16	0=DC*, 1=AC, 2=External
41424	RW	DI7 Mode	UINT16	0~23 (See Note 1), 0* (Common state)
41425	RW	DI7 Type	UINT16	0=NO* (Normally Open), 1=NC (Normally Closed)
41426	RW	DI7 Debounce Time	UINT16	20~9999 (ms), 40*
41427	RW	DI7 Excitation Source	UINT16	0=DC*, 1=AC, 2=External
41428	RW	DI8 Mode	UINT16	0~23 (See Note 1), 0* (Common State)
41429	RW	DI8 Type	UINT16	0=NO* (Normally Open), 1=NC (Normally Closed)
41430	RW	DI8 Debounce Time	UINT16	20~9999 (ms), 40*
41431	RW	DI8 Excitation Source	UINT16	0=DC*, 1=AC, 2=External

Table 5-17 DI Setting

Notes:

- The following table illustrates the options for DI Mode. For Local/Remote control switch, KMA State, KMB State and QF State, only one DI can be configured with the same function.

Value	Option	Value	Option	Value	Option	Value	Option
0	Common State	6	Remote Start B	12	Start Block	18	Emergency Start A
1	Local/Remote	7	Local Start A	13	Remote Stop	19	Emergency Start B
2	Interlock	8	Local Start B	14	Local Stop	20	Local FWD
3	Stop	9	KMA State	15	Reset Protection	21	Local REV
4	Emergency Stop	10	KMB State	16	Remote FWD	22	FWD
5	Remote Start A	11	QF State	17	Remote REV	23	REV

Table 5-18 DI Mode Options

- Set the **DIx Excitation Source** to **External** if the DI is energized with PMC-KI Converter.

5.7.4 DO Setting

Register	Property	Description	Format	Range/Options, Default*
41500	RW	DO1 Mode	UINT16	0~11 (See Note), 1* (Trip Contactor)
41501	RW	DO1 Pulse Width	UINT16	0~9999 (x0.01s), 100* (0 means Latch mode)
41502	RW	DO2 Mode	UINT16	0~11 (See Note), 0* (Spare)
41503	RW	DO2 Pulse Width	UINT16	0~9999 (x0.01s), 100* (0 means Latch mode)
41504	RW	DO3 Mode	UINT16	0~11 (See Note), 3* (Start A)
41505	RW	DO3 Pulse Width	UINT16	0~9999 (x0.01s), 100* (0 means Latch mode)
41506	RW	DO4 Mode	UINT16	0~11 (See Note), 6* (Trip Air Circuit Breaker)
41507	RW	DO4 Pulse Width	UINT16	0~9999 (x0.01s), 100* (0 means Latch mode)
41508	RW	DO5 Mode	UINT16	0~11 (See Note), 5* (Alarm)
41509	RW	DO5 Pulse Width	UINT16	0~9999 (x0.01s), 100* (0 means Latch mode)

Table 5-19 DO Setting

Notes:

- The following table illustrates the options for DO Mode.

Value	Option	Value	Option	Value	Option	Value	Option
0	Spare	3	Start A	6	Trip Air Circuit Breaker	9	R2
1	Trip Contactor	4	Start B	7	Trip Cooler/S-Motor	10	R3
2	Self-check	5	Alarm	8	R1	11	Motor Running

Table 5-20 DO Mode Options

5.7.5 Programmable Logic

5.7.5.1 Programmable Logic Event Description

Register	Property	Description	Format	Notes
41700~41706	RW	Programmable logic trip event 1 description	CHAR	Less than 14 characters
41707~41713	RW	Programmable logic trip event 2 description	CHAR	Less than 14 characters
41714~41720	RW	Programmable logic trip event 3 description	CHAR	Less than 14 characters

41721~41727	RW	Programmable logic alarm event 1 description	CHAR	Less than 14 characters
41728~41734	RW	Programmable logic alarm event 2 description	CHAR	Less than 14 characters
41735~41741	RW	Programmable logic alarm event 3 description	CHAR	Less than 14 characters
41742~41748	RW	Programmable logic trip ACB event 1 description	CHAR	Less than 14 characters
41749~41755	RW	Programmable logic trip ACB event 2 description	CHAR	Less than 14 characters
41756~41762	RW	Programmable logic trip ACB event 3 description	CHAR	Less than 14 characters
41763~41769	RW	Programmable logic event 1 description	CHAR	Less than 14 characters
41770~41776	RW	Programmable logic event 2 description	CHAR	Less than 14 characters
41777~41783	RW	Programmable logic event 3 description	CHAR	Less than 14 characters

Table 5-21 Programmable Logic Event Description

5.7.5.2 Programmable Logic Control Data

Register	Property	Description	Format	Range, Default*
41600	RW	mbCtrlD1	UINT32	0~0xFFFFFFFF, 0*
41602	RW	mbCtrlD2	UINT32	0~0xFFFFFFFF, 0*
41604	RW	mbCtrlD3	UINT32	0~0xFFFFFFFF, 0*
41606	RW	mbCtrlD4	UINT32	0~0xFFFFFFFF, 0*

Table 5-22 Programmable Logic Configurable Variable

5.7.5.3 Programmable Logic Control Command

Register	Property	Description	Format	Range/Option
60150	WO	mbCtrlC1	UINT16	0xFF00/0x0000
60151	WO	mbCtrlC2	UINT16	0xFF00/0x0000
60152	WO	mbCtrlC3	UINT16	0xFF00/0x0000
60153	WO	mbCtrlC4	UINT16	0xFF00/0x0000
60154	WO	mbCtrlC5	UINT16	0xFF00/0x0000
60155	WO	mbCtrlC6	UINT16	0xFF00/0x0000
60156	WO	mbCtrlC7	UINT16	0xFF00/0x0000
60157	WO	mbCtrlC8	UINT16	0xFF00/0x0000

Table 5-23 Programmable Logic Control Command

5.8 Data Logging

5.8.1 Protection Log

The **Protection log pointer** (register 0000) points to the location within the **Protection Log** where the next event will be stored. The following formula is used to determine the register address of the most recent protection event referred by **Protection log pointer** value: Register Address = 45000 + Modulo [**Protection log pointer**-1] / 64] *22.

Register	Property	Description	Format
45000~45021	RO	Event 1	See Table 5-25
45022~45043	RO	Event 2	
45044~45065	RO	Event 3	
...	RO	...	
46386~46407	RO	Event 64	

Table 5-24 Protection Logs

Note:

1. Protection log data structure.

Offset	Properties	Description	Format	Note
+0	RO	High-order Byte: Event Classification	UINT16	See Appendix A
		Low-order Byte: Sub-Classification		See Appendix A
+1	RO	High-order Byte: Year	Timestamp	0-99 (Year-2000)
		Low-order Byte: Month		1 to 12
+2	RO	High-order Byte: Day		1 to 31
		Low-order Byte: Hour		0 to 23
+3	RO	High-order Byte: Minute		0 to 59
		Low-order Byte: Second		0 to 59
+4	RO	Millisecond	0 to 999	
+5	RO	High-order Byte: Protection Level: 0=Alarm, 1=Trip	UINT16	
	RO	Low-order Byte: Status (1/2)		
+6~+19	RO	Event Value	See Appendix A	
+20	RO	High-order Byte: Protection Type Low-order Byte: Error Code	See Table 5-26	
+21	RO	Reserved		

Table 5-25 Protection log data structure

Protection Type	Error Code	Description
1=Phase Current Loss	1	Loss of IA
	2	Loss of IB
	3	Loss of IC
3=Ground Fault	1	Phase A Ground Fault
	2	Phase B Ground Fault
	3	Phase C Ground Fault
	4	Phase AB Ground Fault
	5	Phase BC Ground Fault
	6	Phase CA Ground Fault
	7	Phase ABC Ground Fault
4=LOP	1	Loss of UA
	2	Loss of UB
	3	Loss of UC
	4	Loss of UAB
	5	Loss of UBC
	6	Loss of UCA
	7	ABC Phase Loss
5=Short Circuit	1	Phase A Ground Fault
	2	Phase B Ground Fault
	3	Phase C Ground Fault
	4	Phase AB Ground Fault
	5	Phase BC Ground Fault
	6	Phase CA Ground Fault
	7	Phase ABC Ground Fault
	8	Phase AB P-P Short
	9	Phase BC P-P Short
	10	Phase CA P-P Short
	11	Phase ABC Short Circuit
8=Phase Reversal	1	Voltage Phase Sequence Error
	2	Current Phase Sequence Error
	3	Voltage/Current Phase Sequence Error

Table 5-26 Protection Diagnostic Code

5.8.2 SOE Log

The **SOE log pointer** (register 0002) points to the location within the **SOE Log** where the next event will be stored. The following formula is used to determine the register address of the most recent event referred by **SOE log pointer** value: Register Address = 47000 + Modulo [SOE log pointer-1] / 64] * 8.

Register	Property	Description	Format
47000~47007	RO	Event 1	See Table 5-28
47008~47015	RO	Event 2	
47016~47023	RO	Event 3	
...	RO	...	
47504~47511	RO	Event 64	

Table 5-27 SOE Log

Note:

- SOE log data structure.

Offset	Properties	Description	Format	Note
+0	RO	High-order Byte: Event Classification	UINT16	See Appendix A
		Low-order Byte: Sub-Classification		See Appendix A
+1	RO	High-order Byte: Year	Timestamp	0-99 (Year-2000)
		Low-order Byte: Month		1 to 12
+2	RO	High-order Byte: Day		1 to 31
		Low-order Byte: Hour		0 to 23
+3	RO	High-order Byte: Minute		0 to 59
		Low-order Byte: Second		0 to 59
+4	RO	Millisecond	0 to 999	
+5	RO	High-order Byte: Protection Level (0=Normal, 1=Alarm, 2=Trip)	UINT16	
	RO	Low-order Byte: DI/DI Operation (1=Open, 2=Close)		
+6~+7	RO	Event Value		See Appendix A

Table 5-28 SOE Log Data Structure

5.8.3 Start Report

The **Start pointer** (register 0004) points to the location within the **Start Report** where the next report will be stored. The following formula is used to determine the register address of the most recent Start Report referred by **Start Report pointer** value: Register

Address = 15000 + Modulo [Start Report pointer-1] / 64] * 12.

Register	Property	Description	Format
15000~15011	RO	Report 1	See Table 5-30
15012~12023	RO	Report 2	
15024~15035	RO	Report 3	
...	RO	...	
15756~15767	RO	Report 64	

Table 5-29 Start Report

Note:

1. Start Report data structure.

Offset	Properties	Description	Format	Note
+0	RO	High-order Byte: Event Classification (6=Start)	UINT16	See Table 5-31
		Low-order Byte: Trigger Source		
+1	RO	High-order Byte: Year	Timestamp	0-99 (Year-2000)
		Low-order Byte: Month		1 to 12
+2	RO	High-order Byte: Day		1 to 31
		Low-order Byte: Hour		0 to 23
+3	RO	High-order Byte: Minute		0 to 59
		Low-order Byte: Second		0 to 59
+4	RO	Millisecond		0 to 999
+5	RO	High-order Byte: Reserved	UINT16	--
		Low-order Byte: motor status after start (0=stop, 1=start, 2=running, 3=FWD, 4=REV, 5=Speed 1, 6=Speed 2)		
+6	RO	Maximum starting current (x0.001A)	UINT32	
+8	RO	Motor start time (x0.01s)	UINT32	
+10	RO	Minimum starting voltage (x0.01V)	UINT32	

Table 5-30 Start Report Data Structure

2. The following table illustrates all the motor start trigger source.

Value	Control Source	Value	Control Source	Value	Control Source	Value	Control Source
0	Unknown	5	DI5 Control	18	Modbus Control	23	External Source
1	DI1 Control	6	DI6 Control	19	Profibus Control	24	Quick Start
2	DI2 Control	7	DI7 Control	20	Programmable Logic		
3	DI3 Control	8	DI8 Control	21	Undervoltage Restart		
4	DI4 Control	17	Front Panel Control	22	Auto-start		

Table 5-31 Start Trigger Source

5.8.4 Stop Report

The **Stop pointer** (register 0005) points to the location within the **Stop Report** where the next report will be stored. The following formula is used to determine the register address of the most recent Stop Report referred by **Stop Report pointer** value: Register Address = 18000 + Modulo [Stop Report pointer-1] / 64] * 12.

Register	Property	Description	Format
18000~18011	RO	Report 1	See Table 5-33
18012~18023	RO	Report 2	
18024~18035	RO	Report 3	
...	RO	...	
18756~18767	RO	Report 64	

Table 5-32 Stop Report

Note:

1. Stop Report data structure.

Offset	Properties	Description	Format	Note
+0	RO	High-order Byte: Event Classification (7=Stop)	UINT16	See Table 5-34
		Low-order Byte: Trigger Source		
+1	RO	High-order Byte: Year	Timestamp	0-99 (Year-2000)
		Low-order Byte: Month		1 to 12
+2	RO	High-order Byte: Day		1 to 31
		Low-order Byte: Hour		0 to 23
+3	RO	High-order Byte: Minute		0 to 59
		Low-order Byte: Second		0 to 59
+4	RO	Millisecond		0 to 999
+5	RO	Reserved	--	--
+6	RO	IA (x0.001A)	UINT32	
+8	RO	IB (x0.001A)	UINT32	
+10	RO	IC (x0.001A)	UINT32	

Table 5-33 Stop Report Data Structure

2. The following table illustrates all the motor stop trigger source.

Value	Control Source	Value	Control Source	Value	Control Source	Value	Control Source
0	Unknown	6	DI6 Control	20	Programmable Logic	26	Change Speed
1	DI1 Control	7	DI7 Control	21	External Source	27	Start Block
2	DI2 Control	8	DI8 Control	22	Voltage Interruption	28	Protection Trip
3	DI3 Control	17	Front Panel Control	23	DP Comm. Interrupt		
4	DI4 Control	18	Modbus Control	24	Control Para. Update		
5	DI5 Control	19	Profibus Control	25	Switch Direction		

Table 5-34 Stop Trigger Source

5.9 Data Recorder

The relay can store up to 10000 entries DR log. Retrieve the newest DR logs through writing the entry number which you can get from **DR log pointer (register 0006)** into **DR log index (register 20000)**. For example, if the value for **DR log pointer** is 10500, then you can write 10500 to 501 into 20000 register where 10500 means the newest logs and 501 means the oldest logs.

Register	Property	Description	Format	Note
20000	RW	Data Log Index	UINT32	
20002	RO	High-order Byte: Year	Timestamp	0-99 (Year-2000)
		Low-order Byte: Month		1 to 12
20003	RO	High-order Byte: Day		1 to 31
		Low-order Byte: Hour		0 to 23
20004	RO	High-order Byte: Minute		0 to 59
		Low-order Byte: Second		0 to 59
20005	RO	Millisecond		0 to 999
20006	RO	UAB	FLOAT	
20008	RO	UBC	FLOAT	
20010	RO	UCA	FLOAT	
20012	RO	IA	FLOAT	
20014	RO	IB	FLOAT	
20016	RO	IC	FLOAT	
20018	RO	kW Total	FLOAT	

Table 5-35 Data Recorder Log Structure

5.10 Control Operations

The Alarm/DO Control registers are implemented as both “Write-Only” Modbus Coil Registers (0XXXXX) and Modbus Holding Registers (4XXXXX), which can be controlled with the Force Single Coil command (Function Code 0x05) or the Preset Multiple Hold Registers (Function Code 0x10). The relay does not support the Read Coils command (Function Code 0x01) because Alarm/DO Control registers are “Write-Only”. The DO Status register 0017 should be read instead to determine the current DO status.

The relay adopts the ARM before EXECUTE operation for the remote control of its Digital Outputs if this function is enabled through the **DO Remote Setup register (41031)**, which is disabled by default. Before executing an OPEN or CLOSE command on a Relay Output, it must be “Armed” first. This is achieved by writing the value 0xFF00 to the appropriate register to “Arm” a particular DO operation. The DO will be “Disarmed” automatically if an “Execute” command is not received within 15 seconds after it has been “Armed”. If an “Execute” command is received without first having received an “Arm” command, the meter ignores the “Execute” command and returns the 0x04 exception code.

Register	Property	Description	Format	Note
60064	WO	Arm DO1 Close	UINT16	Writing "0xFF00" to the register to execute the described action.
60065	WO	Execute DO1 Close	UINT16	
60066	WO	Arm DO1 Open	UINT16	
60067	WO	Execute DO1 Open	UINT16	
60068	WO	Arm DO2 Close	UINT16	
60069	WO	Execute DO2 Close	UINT16	
60070	WO	Arm DO2 Open	UINT16	
60071	WO	Execute DO2 Open	UINT16	
60072	WO	Arm DO3 Close	UINT16	
60073	WO	Execute DO3 Close	UINT16	
60074	WO	Arm DO3 Open	UINT16	
60075	WO	Execute DO3 Open	UINT16	
60076	WO	Arm DO4 Close	UINT16	
60077	WO	Execute DO4 Close	UINT16	
60078	WO	Arm DO4 Open	UINT16	
60079	WO	Execute DO4 Open	UINT16	
60080	WO	Arm DO5 Close	UINT16	
60081	WO	Execute DO5 Close	UINT16	
60082	WO	Arm DO5 Open	UINT16	
60083	WO	Execute DO5 Open	UINT16	
60084~601233	--	Reserved	--	--
60124	WO	Remote Start A	UINT16	Writing "0xFF00" to the register to execute the described action.
60125	WO	Remote Stop	UINT16	
60126	WO	Remote Start B	UINT16	
60127	--	Reserved	--	--
60128	WO	Arm Protection Reset ¹		Writing "0xFF00" to the register to execute the described action.
60129	WO	Execute Protection Reset ¹	UINT16	
60130	WO	Manual Trigger Waveform Recorder	UINT16	

Table 5-36 DO Control

Note:

1. To execute the Protection Reset on the relay, it is required to send an "Arm Protection Reset" request first. And within 15 seconds, the "Execute Protection Reset" request must be received subsequently.

5.11 Time Registers

There are two sets of Time registers supported by the relay - Year/Month/Day/Hour/Minute/Second (Registers # 60000 to 60002 for 6-digit addressing and Registers # 9000 to 9002 for 5-digit addressing) and UNIX Time (Registers # 60004 to 60005 for 6-digit addressing and Registers # 9004 to 9005 for 5-digit addressing). When sending time to the relay over Modbus communications, care should be taken to only write one of the two Time register sets. All registers within a Time register set must be written in a single transaction. If registers 60000 to 60004 (or 9000 to 9004 for 5-digit addressing) are being written to at the same time, both Time register sets will be updated to reflect the new time specified in the UNIX Time register set 60004 (9004) where the time specified in registers 60000 to 60003 (9000-9003 for 5-digit addressing) will be ignored. Writing to the Millisecond register 60003 (9003 for 5-digit addressing) is optional during a Time Set operation. When broadcasting time, the function code must be set to 0x10 (Pre-set Multiple Registers). Incorrect date or time values will be rejected by the meter.

Register	Property	Description	Format	Note
60000	9000	RW	High-order Byte: Year	0-99 (Year-2000)
			Low-order Byte: Month	
60001	9001	RW	High-order Byte: Day	1 to 31
			Low-order Byte: Hour	0 to 23
60002	9002	RW	High-order Byte: Minute	0 to 59
			Low-order Byte: Second	0 to 59
60003	9003	RW	Millisecond	0 to 999
60004 ~ 60005	9004 ~ 9005	RW	UNIX Time	0x386D4380 to 0xf48656FF The corresponding time is 2000.01.01 00:00:00 to 2099.12.31 23:59:59 (GMT 0:00 Time Zone)

Table 5-37 Time Registers

5.12 Device Information

Register	Property	Description	Format	Note
60200~60219	RO	Meter Model	CHAR	See Note 1
60220	RO	Firmware Version	UINT16	e.g., 10000 shows the version is V1.00.00
60221	RO	Modbus Version	UINT16	e.g., 10 shows the version is V1.0
60222	RO	Firmware Date: Year-2000	UINT16	e.g., 130709 means July 9, 2013
60223	RO	Firmware Date: Month	UINT16	
60224	RO	Firmware Date: Day	UINT16	
60225	RO	Serial Number	UINT32	
60227~60228	--	Reserved	--	
60229	RO	Start Control Mode	UINT16	0=Direct-on-line, 1=Reduce-voltage, 2=FWD-REV, 3=2-Speed, 5=VFD Start, 6=L-Motor Start
60230	RO	I/O Feature	UINT16	0=8DI+5DO, 1=8DI+4DO+1AO, 2=6DI+5DO+1AO

Table 5-38 Device Information

Note:

- The **Meter Model** appears in registers 60200 to 60219 and contains the ASCII encoding of the string "PMC-550J" as shown in the following table.

Register	Value(Hex)	ANSII
60200	0x50	P
60201	0x4D	M
60202	0x43	C
60203	0x2D	-
60204	0x35	5
60205	0x35	5
60206	0x30	0
60207	0x4A	J
60208~60219	0x20	(space)

Appendix A – SOE and Protection Log Classifications

Classification	Sub-Classification	Status	Description	Event Value	
1=DI/DO Change	1	1/2	DI1 Open / DI1 Close	DIx Function (UINT32): 0~23 0=Common State, 1=Local/Remote, 2=Interlock 3=Stop, 4=Emergency Stop, 5=Remote Start A 6=Remote Start B, 7=Local Start A, 8=Local Start B 9=KMA State, 10=KMB State, 11=QF State 12=Start Block, 13=Remote Stop, 14=Local Stop 15=Reset Protection, 16=Remote FWD 17=Remote REV, 18=Emergency Start A 19=Emergency Start B, 20=Local FWD, 21=Local REV 22=FWD, 23=REV	
	2	1/2	DI2 Open / DI2 Close		
	3	1/2	DI3 Open / DI3 Close		
	4	1/2	DI4 Open / DI4 Close		
	5	1/2	DI5 Open / DI5 Close		
	6	1/2	DI6 Open / DI6 Close		
	7	1/2	DI7 Open / DI7 Close		
	8	1/2	DI8 Open / DI8 Close		
	11	1/2	DO1 Return / DO1 Act		DOx Function (UINT32): 0~11 0=Spare, 1=Trip Contactor, 2=Self-check, 3=Start A 4=Start B, 5=Alarm, 6=Trip Air Circuit Breaker 7=Trip Cooler/S-Motor, 8=R1, 9=R2, 10=R3 11=Motor Running
	12	1/2	DO2 Return / DO2 Act		
	13	1/2	DO3 Return / DO3 Act		
	14	1/2	DO4 Return / DO4 Act		
	15	1/2	DO5 Return / DO5 Act		
	2=Protection Log	1	2	Short Circuit Trip	Record Value: +0 (UINT32): IA, x0.001A) +2 (UINT32): IB (UINT32, x0.001A) +4 (UINT32): IC (UINT32, x0.001A) +6 (UINT32): IN/3I0 (x0.001A) +8 (UINT32): UAB (x0.01V) +10 (UINT32): UBC (x0.01V) +12 (UINT32): UCA (x0.01V)
		2	2	Jam Trip	
3		2	Overload Trip		
4		2	Thermal Overload Trip		
5		2	Ground Fault Trip		
6		2	Imbalance Trip	Record Value: +0 (UINT32): IA, x0.001A) +2 (UINT32): IB (UINT32, x0.001A) +4 (UINT32): IC (UINT32, x0.001A) +6 (UINT32): Imbalance (x0.1%) +8 (UINT32): UAB (x0.01V) +10 (UINT32): UBC (x0.01V) +12 (UINT32): UCA (x0.01V)	
7		2	Phase Current Loss Trip	Record Value: +0 (UINT32): IA, x0.001A) +2 (UINT32): IB (UINT32, x0.001A) +4 (UINT32): IC (UINT32, x0.001A) +6 (UINT32): IN/3I0 (x0.001A) +8 (UINT32): UAB (x0.01V) +10 (UINT32): UBC (x0.01V) +12 (UINT32): UCA (x0.01V)	
8		2	Undervoltage Trip		
9		2	Overvoltage Trip		
10		2	tE Trip		
11		2	Long Start Trip		
12		2	Interlock Trip		
13		2	Underload Trip		
14		2	Under Power Trip		
15		2	Residual Current Trip	Record Value: +0 (UINT32): IA (x0.001A) +2 (UINT32): IB (x0.001A) +4 (UINT32): IC (x0.001A) +6 (UINT32): Ir (mA) +8 (UINT32): UAB (x0.01V) +10 (UINT32): UBC (x0.01V) +12 (UINT32): UCA (x0.01V)	
16		2	Phase Reversal Trip	Record Value: +0 (UINT32): IA, x0.001A) +2 (UINT32): IB (UINT32, x0.001A) +4 (UINT32): IC (UINT32, x0.001A) +6 (UINT32): IN/3I0 (x0.001A) +8 (UINT32): UAB (x0.01V) +10 (UINT32): UBC (x0.01V) +12 (UINT32): UCA (x0.01V)	

17	2	Undervoltage Restart	Record Value: +0 (INT32): 3-Phase Ull Min. Start (x0.01V) +2 (INT32): Phase of 3-Phase Ull Min. Start +4 (INT32): 3-Phase Ull Min. End (x0.01V) +6 (INT32): Phase of 3-Phase Ull Min. End +8 (UINT32): Undervoltage Duration (x0.01s) +10 (BITMAP): Bit0~Bit7 stands for DI1~DI8 status, Bit16~Bit20 stands for DO1~DO5 status 0 means Open while 1 means Close +12 (UINT32): Failure Reason: 0
18	2	Reduce-voltage Start	Record Value: +0 (UINT32): IA (x0.001A) +2 (UINT32): IB (x0.001A) +4 (UINT32): IC (x0.001A) +6 (UINT32): 0=Fail, 1=Succeed +8 (UINT32): UAB (x0.01V) +10 (UINT32): UBC (x0.01V) +12 (UINT32): UCA (x0.01V)
19	2	Short Circuit Alarm	Record Value: +0 (UINT32): IA, x0.001A +2 (UINT32): IB (UINT32, x0.001A) +4 (UINT32): IC (UINT32, x0.001A) +6 (UINT32): IN/3I0 (x0.001A) +8 (UINT32): UAB (x0.01V) +10 (UINT32): UBC (x0.01V) +12 (UINT32): UCA (x0.01V)
20	2	Jam Alarm	
21	2	Overload Alarm	
22	2	Thermal Overload Alarm	
23	2	Ground Fault Alarm	
24	2	Imbalance Alarm	
25	2	Phase Current Loss Alarm	
26	2	Undervoltage Alarm	Record Value: +0 (UINT32): IA, x0.001A +2 (UINT32): IB (UINT32, x0.001A) +4 (UINT32): IC (UINT32, x0.001A) +6 (UINT32): IN/3I0 (x0.001A) +8 (UINT32): UAB (x0.01V) +10 (UINT32): UBC (x0.01V) +12 (UINT32): UCA (x0.01V)
27	2	Overvoltage Alarm	
28	2	tE Alarm	
29	2	Long Start Alarm	
30	2	Interlock Alarm	
31	2	Underload Alarm	
32	2	Under Power Alarm	
33	2	Residual Current Alarm	Record Value: +0 (UINT32): IA (x0.001A) +2 (UINT32): IB (x0.001A) +4 (UINT32): IC (x0.001A) +6 (UINT32): Ir (mA) +8 (UINT32): UAB (x0.01V) +10 (UINT32): UBC (x0.01V) +12 (UINT32): UCA (x0.01V)
34	2	LOP Alarm	Record Value: +0 (UINT32): IA, x0.001A +2 (UINT32): IB (UINT32, x0.001A) +4 (UINT32): IC (UINT32, x0.001A) +6 (UINT32): IN/3I0 (x0.001A) +8 (UINT32): UAB (x0.01V) +10 (UINT32): UBC (x0.01V) +12 (UINT32): UCA (x0.01V)
35	2	Contactora Abnormal Trip	
36	1	Auto-Restart	
37	2	Emergency Stop Alarm	
38	2	Circuit Breaker Failure Trip	
39	2	Circuit Breaker Failure Alarm	
40	2	Contactora Protection Act	
41	2	Contactora Failure Protection Act	
42	2	ACB Trip Contactora	

CET Electric Technology

43	2	MTA Failure Alarm	<p>Record Value: +0 (UINT32): IA (x0.001A) +2 (UINT32): IB (x0.001A) +4 (UINT32): IC (x0.001A) +6 (BITMAP): BIT0~BIT2 stands for Phase A to Phase C, 1 means Error +8 (UINT32): UAB (x0.01V) +10 (UINT32): UBC (x0.01V) +12 (UINT32): UCA (x0.01V)</p>
44	2	Phase Reversal Alarm	<p>Record Value: +0 (UINT32): IA, x0.001A) +2 (UINT32): IB (UINT32, x0.001A) +4 (UINT32): IC (UINT32, x0.001A) +6 (UINT32): IN/3I0 (x0.001A) +8 (UINT32): UAB (x0.01V) +10 (UINT32): UBC (x0.01V) +12 (UINT32): UCA (x0.01V)</p>
45	2	Contactora Abnormal Alarm	<p>Record Value: +0 (UINT32): IA (x0.001A) +2 (UINT32): IB (x0.001A) +4 (UINT32): IC (x0.001A) +6 (UINT32): I2 (x0.001A) +8 (UINT32): UAB (x0.01V) +10 (UINT32): UBC (x0.01V) +12 (UINT32): UCA (x0.01V)</p>
46	2	Negative Sequence Trip	<p>Record Value: +0 (UINT32): IA (x0.001A) +2 (UINT32): IB (x0.001A) +4 (UINT32): IC (x0.001A) +6 (UINT32): I2 (x0.001A) +8 (UINT32): UAB (x0.01V) +10 (UINT32): UBC (x0.01V) +12 (UINT32): UCA (x0.01V)</p>
47	2	Negative Sequence Alarm	<p>Record Value: +0 (UINT32): IA (x0.001A) +2 (UINT32): IB (x0.001A) +4 (UINT32): IC (x0.001A) +6 (UINT32): I2 (x0.001A) +8 (UINT32): UAB (x0.01V) +10 (UINT32): UBC (x0.01V) +12 (UINT32): UCA (x0.01V)</p>
48	2	Thermal OL (Overload) Pre-alarm Act	<p>Record Value: +0 (UINT32): IA (x0.001A) +2 (UINT32): IB (x0.001A) +4 (UINT32): IC (x0.001A) +6 (UINT32): I2 (x0.001A) +8 (UINT32): UAB (x0.01V) +10 (UINT32): UBC (x0.01V) +12 (UINT32): UCA (x0.01V)</p>
50	2	Forward-Reverse Start Fail	<p>Record Value: +0 (UINT32): IA (x0.001A) +2 (UINT32): IB (UINT32, x0.001A) +4 (UINT32): IC (UINT32, x0.001A) +6 (UINT32): 0 (Reserved) +8 (UINT32): UAB (x0.01V) +10 (UINT32): UBC (x0.01V) +12 (UINT32): UCA (x0.01V)</p>
51	2	2-Speed Start Fail	<p>Record Value: +0 (INT32): 3-Phase Ull Min. Start (x0.01V) +2 (INT32): Phase of 3-Phase Ull Min. Start +4 (INT32): 3-Phase Ull Min. End (x0.01V) +6 (UINT32): Failure Reason 1=Long Voltage Dip with Motor Stop 2=Dip Duration + Restart Delay > Allowed Time 3= No Voltage 4= KM Closed 5= Motor Ie ≠ 0 +8 (INT32): Phase of 3-Phase Ull Min. End +10 (UINT32): Undervoltage Duration (x0.01s) +12 (BITMAP): Bit0~Bit7 stands for DI1~DI8 status, Bit16~Bit20 stands for DO1~DO5 status 0 means Open while 1 means Close</p>
52	2	VFD Start Fail	
53	2	L-Motor Start Fail	
54	2	Undervoltage Restart Fail	
55	1	Quick Restart Fail	<p>Record Value: +0 (UINT32): IA (x0.001A) +2 (UINT32): IB (x0.001A) +4 (UINT32): IC (x0.001A) +6 (UINT32): IN/3I0 (x0.001A) +8 (UINT32): UAB (x0.01V) +10 (UINT32): UBC (x0.01V) +12 (UINT32): UCA (x0.01V)</p>

	56	2	Invalid Start Command	Record Value: +0 (UINT32): Start Command Type 1=Start A, 2=Start B +2 (UINT32): Start Command Source 0=Unknown, 1~8=DI1~DI8 Control, 17=Front Panel Control, 18=Modbus Control 19=Profibus Control, 20=PL Control, 21=Undervoltage Restart, 22=Auto-Restart 23=External, 24=Quick Start +4 (UINT32): Result 1=Succeed, 2=Fail-Permission Mismatch 3=Fail-Motor Started/Running 4=Fail-Start Block 5=Fail-Start Mismatch
	57	2	Invalid Stop Command	Record Value: +0 (UINT32): Stop Command Type 3=Stop +2 (UINT32): Stop Command Source 0=Unknown, 1~8=DI1~DI8 Control 17=Front Panel Control, 18=Modbus Control 19=Profibus Control, 20=PL Control 21=External, 22=Voltage Interruption 23=DP Communication Interrupt 24=Control Parameters Update 25=Switch Direction (in FWD-REV application) 26=Change Speed (in 2-Speed application) 27=Start Block, 28=Protection Trip +4 (UINT32): Result 1=Succeed, 2=Fail-Permission Mismatch
	60	2	PLC1 Trip	Record Value: +0 (UINT32): IA (x0.001A) +2 (UINT32): IB (x0.001A) +4 (UINT32): IC (x0.001A) +6 (UINT32): IN/3I0 (x0.001A) +8 (UINT32): UAB (x0.01V) +10 (UINT32): UBC (x0.01V) +12 (UINT32): UCA (x0.01V)
	61	2	PLC2 Trip	
	62	2	PLC3 Trip	
	63	2	PLC1 Alarm	
	64	2	PLC2 Alarm	
	65	2	PLC3 Alarm	
	66	2	PLC1 Trip ACB	
	67	2	PLC2 Trip ACB	
	68	2	PLC3 Trip ACB	
	69	2	PLC Event 1	
	70	2	PLC Event 2	
	71	2	PLC Event 3	
	101	2	PLC Trigger WFR	Record Value: +0 (UINT32): IA (x0.001A) +2 (UINT32): IB (x0.001A) +4 (UINT32): IC (x0.001A) +6 (UINT32): 0 (Reserved) +8 (UINT32): UAB (x0.01V) +10 (UINT32): UBC (x0.01V) +12 (UINT32): UCA (x0.01V)
3=Diagnostic Log	1	2	Metering Error	Record Value: +0 (UINT16): DC Bias Voltage (x0.001V) +1 (BITMAP): 0 means normal while 1 means Error Bit0 stands for UAB channel, Bit1 Stands for UBC channel, Bit2 stands for IA channel, Bit3 stands for IB channel, Bit4 stands for IC channel, Bit5 stands for Ir channel
	2	2	Device Parameter Error	0
	3	2	Protection Parameter Error	0
	4	2	Calibration Parameter Error	0
	5	2	Setup Parameter Error	0
	6	2	FRAM Error	0
	8	2	FLASH Error	0
	9	2	First Power On	0
4=Operation Log	1	--	Power Off	0
	2	--	Power On	0
	3	--	Clear SOE and Protection Log	0
	4	--	Clear Energy	0
	5	--	Clear Statistics	0
	6	--	Clear Start Report	0

CET Electric Technology

7	--	Clear Stop Report	0
8	--	Clear Waveform Recorder	0
9	--	Clear Data Recorder	0
10	--	Reset Protection via Front Panel	0
11	--	Reset Protection Remotely	0
12	--	Preset Energy	0
13	--	Change Date/Time	0
14	--	Change Password	0
15	--	Restore Device Parameters	0
16	--	Calibration Reset	0
17	--	Factory Reset	0
18	--	Set System Parameters	0
19	--	Set DI Parameters	0
20	--	Set DO Parameters	0
21	--	Set Communication Parameters	0
22	--	Set Protection Parameters	0
23	--	Set Control Parameters	0
24	--	Set AO Parameters	0
25	1/2	Set DR Parameters	0
26	1/2	Enter/Exit Comm. Test	0
27		Reserved	
28	--	Trigger WFR Remotely	0
29	--	Manual Trigger WFR	0

Appendix B – Technical Specification

Voltage Inputs (VA, VB, VC)		
Standard (Vn)	400VLN/690VLL	
Range	10V to 828V for 690VLL	
Overload	1.2xVn continuous, 1.4xVn for 10s	
Burden	<0.75VA per phase	
Frequency	50Hz/60Hz	
Current Inputs		
Plug-in Current Sensor PMC-MTAs (IA, IB, IC, IN)		
Ie	1A/5A/25A/100A/300A/400A/800A	
Range	5% to 120% Ie	
Overload	10xIe for 10s	
Optional Residual Current Sensor PMC-MIR (IR1, IR2)		
Primary (In)	1A	
Secondary	1V	
I _{max}	5In continually	
Optional Zero Sequence Current Sensor PMC-MIN (I41, I42)		
Primary (In)	1A/5A	
Secondary	1V	
Range	5% to 120% In	
I _{max}	10In	
Power Supply (L/+, N/-)		
Standard	95-250VAC/DC	
Optional	Enhanced power supply (ride-through capability)	
Burden	<5W	
Digital Inputs (DIC, DI1, DI2, DI3, DI4, DI5, DI6, DI7, DI8)		
Standard	Dry contact, 24VDC internally wetted	
Debounce Time	20~9999ms programmable	
Relay Outputs (DO11, DO12, DO21, DO22, DO31, DO32, DO41, DO42, DO51, DO52)		
Type	DO1 Form B (NC), DO2 Form A (NO) or Form B (NC), DO3 to DO5 Form A (NO)	
Contact Rating	DO1 to DO4 250VAC/24VDC, 8A	DO5 250VAC/30VDC, 5A
Max. Switching Voltage	400VAC/30VDC	277VAC/30VDC
Max. Carrying Current	10A	5A
Max. Switching Power	2000VA/192W	1250VA/150W
Operate Time	<10ms	<10ms
Release Time	<5ms	<10ms
Service Life	>20,000,000 cycles (Mechanical) >100,000 cycles (Electrical at rated load)	>5,000,000 cycles (Mechanical) >100,000 cycles (Electrical at rated load)
Internal Clearance/ Creepage Distance	>8mm (Safety Insulation up to 250VAC) (EN61810-1, Pollution Degree 3)	>6mm (Safety Insulation up to 250VAC) (EN61810-1, Pollution Degree 2)
Optional Analog Output (AO+, AO-)		
Load	750 ohms	
Range	4 to 20 mA	
Terminals Max. Torque		
Power Supply, Voltage/Current Inputs, DI, DO, RS-485	3.47in.lb/0.9N.m/4kgf.cm/M2.5	
AO	2.17in.lb/0.25N.m/2.5kgf.cm/M2	
Environmental Conditions		
Operating Temperature	-25°C to 70°C	
Storage Temperature	-40°C to 85°C	
Humidity	5% to 95% non-condensing	
Atmospheric Pressure	70kPa to 106kPa	
Mechanical Characteristics		
Panel Cutout	121x71 mm	
Unit Dimensions	126x76x91 mm	
IP Rating	40	

Appendix C – Accuracy Specification

Parameters	Accuracy	Resolution
Voltage (U)	±0.5%	0.001V
I1, I2, I3	±0.5%	0.001A
IN	±0.5%	0.001A
Ir	20mA to 1200mA: ±1.0%	1mA
	1200mA to 5000mA: ±3.0%	
kW, kvar, kVA	±1.0%	0.001kx
kWh	±1.0%	0.01kWh
kvarh	+2.0%	0.01kvarh
Power Factor	±1.0%	0.001
Frequency	±0.02Hz	0.001Hz
Analog Output	±0.5%	--
Harmonics	IEC 61000-4-7 Class II	0.01%

Appendix D – Relay Elements Specifications

Thermal Overload

Stage: Off, Alarm, Trip, Trip & Alarm
 Iov Setting Range: 1.00 – 10.00 x Ie
 Tc Setting Range: 0.1 – 99.9 seconds
 Pre-alarm Threshold: Off, 1% - 99% x Heat Capacity
 Return Threshold: 0 – 100%
 Accuracy: (≤ 3 seconds) ± 100 ms
 (> 3 seconds) $\pm 5\%$ of pickup

Long Start

Stage: Off, Alarm, Trip, Trip & Alarm
 Time Dial: 0.1 – 99.9 seconds
 Accuracy: (≤ 3 seconds) ± 60 ms
 (> 3 seconds) $\pm 2\%$ of pickup

Jam

Stage: Off, Alarm, Trip, Trip & Alarm
 Setting Range: 1.0 – 10.0 x Ie
 Accuracy: ± 50 mA or $\pm 3\%$ of pickup
 Time Dial: 0.1 – 99.9 seconds
 Accuracy: (≤ 3 seconds) ± 60 ms
 (> 3 seconds) $\pm 2\%$ of pickup

Ground Fault

Stage: Off, Alarm, Trip, Trip & Alarm
 Setting Range: 0.1 – 10.0 x Ie
 Accuracy: ± 50 mA or $\pm 3\%$ of pickup
 Time Dial: (Start State) 0.1 – 99.9 seconds
 (Run State) 0.1 – 99.9 seconds
 Accuracy: (≤ 3 seconds) ± 60 ms
 (> 3 seconds) $\pm 2\%$ of pickup

MTA Failure

Stage: Off, Alarm
 Time Dial: 0.1 – 99.9 seconds
 Accuracy: (≤ 3 seconds) ± 60 ms
 (> 3 seconds) $\pm 2\%$ of pickup

Phase Current Loss

Stage: Off, Alarm, Trip, Trip & Alarm
 Time Dial: 0.1 – 99.9 seconds
 Accuracy: (≤ 3 seconds) ± 60 ms
 (> 3 seconds) $\pm 2\%$ of pickup

Imbalance

Stage: Off, Alarm, Trip, Trip & Alarm
 Setting Range: 10% - 100%
 Accuracy: $\pm 3\%$ of pickup

Under Power

Stage: Off, Alarm, Trip, Trip & Alarm
 Setting Range: 0.10 – 0.95 x Pe
 Accuracy: $\pm 5\%$ of pickup

Short Circuit

Stage: Off, Alarm, Trip, Trip & Alarm
 Setting Range: 1.0 – 10.0 x Ie
 Start Multiple: 1.00 – 2.00
 Accuracy: ± 50 mA or $\pm 3\%$ of pickup
 Time Dial: 0.1 – 99.9 seconds

Undervoltage

Stage: Off, Alarm, Trip, Trip & Alarm
 Setting Range: 0.30 – 0.95 x Ue
 Accuracy: ± 2 V or $\pm 3\%$ of pickup
 Time Dial: 0.1 – 99.9 seconds
 Accuracy: (≤ 3 seconds) ± 60 ms
 (> 3 seconds) $\pm 2\%$ of pickup

Overvoltage

Stage: Off, Alarm, Trip, Trip & Alarm
 Setting Range: 1.05 – 1.60 x Ue
 Accuracy: ± 2 V or $\pm 3\%$ of pickup
 Time Dial: 0.1 – 99.9 seconds
 Accuracy: (≤ 3 seconds) ± 60 ms
 (> 3 seconds) $\pm 2\%$ of pickup

Underload

Stage: Off, Alarm, Trip, Trip & Alarm
 Setting Range: 0.10 – 1.00 x Ie
 Accuracy: ± 50 mA or $\pm 3\%$ of pickup
 Time Dial: 0.1 – 999.9 seconds
 Accuracy: (≤ 3 seconds) ± 60 ms
 (> 3 seconds) $\pm 2\%$ of pickup

tE Time

Stage: Off, Alarm, Trip, Trip & Alarm
 Tp Setting Range: 0.1 – 99.9 seconds
 Accuracy: (≤ 3 seconds) ± 100 ms
 (> 3 seconds) $\pm 5\%$ of pickup

Overload

Stage: Off, Alarm, Trip, Trip & Alarm
 Setting Range: 1.0 – 10.0 x Ie
 Accuracy: ± 50 mA or $\pm 3\%$ of pickup
 Time Dial: 0.1 – 99.9 seconds
 Accuracy: (≤ 3 seconds) ± 60 ms
 (> 3 seconds) $\pm 2\%$ of pickup

Interlock

Stage: Off, Alarm, Trip, Trip & Alarm
 Time Dial: 0.1 – 99.9 seconds
 Accuracy: (≤ 3 seconds) ± 60 ms
 (> 3 seconds) $\pm 2\%$ of pickup

LOP

Stage: Off, Alarm

Phase Reversal

Stage: Off, Alarm, Trip, Trip & Alarm

CB Failure

Stage: Off, Alarm, Trip, Trip & Alarm
 Time Dial: 0.1 – 99.9 seconds
 Accuracy: (≤ 3 seconds) ± 60 ms
 (> 3 seconds) $\pm 2\%$ of pickup

Contactors Protection

Stage: Off, On
 Setting Range: 4.0 – 20.0 x I_e
 Accuracy: ± 50 mA or $\pm 3\%$ of pickup

Contactors Failure

Stage: Off, On
 Setting Range: 0.1 – 5.0 x I_e
 Accuracy: ± 50 mA or $\pm 3\%$ of pickup
 Time Dial: 0.1 – 99.9 seconds
 Accuracy: (≤ 3 seconds) ± 60 ms
 (> 3 seconds) $\pm 2\%$ of pickup

ACB Control Contactor

Stage: Off, On
 Time Dial: 0.1 – 99.9 seconds
 Accuracy: (≤ 3 seconds) ± 60 ms
 (> 3 seconds) $\pm 2\%$ of pickup

Contactors Abnormal

Stage: Off, Alarm, Trip, Trip & Alarm
 Time Dial: 1.0 – 99.9 seconds
 Accuracy: (≤ 3 seconds) ± 60 ms
 (> 3 seconds) $\pm 2\%$ of pickup

Emergency Stop Alarm

Stage: On, Off

Residual Current

Stage: Off, Alarm, Trip, Trip & Alarm
 Setting Range: (Alarm) 20.0 – 5000.0 mA
 (Trip) 20.0 – 5000.0 mA
 Accuracy: ± 50 mA or $\pm 3\%$ of pickup
 Time Dial: (Alarm) 0.0 – 99.9 seconds
 (Trip) 0.0 – 99.9 seconds
 Accuracy: (≤ 3 seconds) ± 60 ms
 (> 3 seconds) $\pm 2\%$ of pickup

Negative Sequence

Stage: Off, Alarm, Trip, Trip & Alarm
 Setting Range: 0.1 – 10.0 x I_e
 Accuracy: ± 50 mA or $\pm 3\%$ of pickup
 Time Dial: (Start State) 0.1 – 99.9 seconds
 (Run State) 0.1 – 99.9 seconds
 Accuracy: (≤ 3 seconds) ± 60 ms
 (> 3 seconds) $\pm 2\%$ of pickup

Appendix E – Standard Compliance

Safety Requirements	
CE LVD 2014 / 35 / EU	EN 61010-1: 2010 + A1: 2019 EN IEC 61010-2-030: 2021
Insulation AC Voltage: 2kV @ 1 minute Insulation Resistance: > 100MΩ Impulse Voltage: 5kV, 1.2/50us	IEC 60255-5: 2000 EN 61010-1: 2010 + A1:2019 EN IEC 61010-2-030: 2021
EMC Compatibility CE EMC Directive 2014 / 30 / EU (EN IEC 61326: 2021)	
Immunity Test	
Electrostatic Discharge	EN 61000-4-2: 2009
Radiated Fields	EN 61000-4-3: 2020
Fast Transients	EN 61000-4-4: 2012
Surges	EN 61000-4-5: 2014 + A1: 2017
Conducted Disturbances	EN 61000-4-6: 2014
Power Frequency Magnetic Fields	EN 61000-4-8: 2010
Pulsed Magnetic Fields	EN 61000-4-9: 2016
Damped Oscillatory Magnetic Fields	EN 61000-4-10: 2017
Voltage Dips and Interruptions	EN IEC 61000-4-11: 2020
Ripple on DC Input Power Port	EN 61000-4-17: 1999 + A2: 2009
Damped Oscillatory Wave	EN IEC 61000-4-18: 2019
Power Frequency Immunity on Binary Inputs	IEC 60255-26: 2013 Class A
Gradual Shut Down / Start-up Tests	IEC 60255-26: 2013
Emission Test	
Limits and Methods of Measurement of Electromagnetic Disturbance Characteristics of Industrial, Scientific and Medical (ISM) Radio-Frequency Equipment	EN 55011: 2016 + A1: 2017 + A2: 2021
Electromagnetic Compatibility of Multimedia Equipment - Emission Requirements	EN 55032: 2015 + AC: 2016 + A11: 2020
Limits for Harmonic Current Emissions for Equipment with Rated Current ≤ 16 A	EN IEC 61000-3-2: 2019 + A1: 2021
Limitation of Voltage Fluctuations and Flicker in Low-Voltage Supply Systems for Equipment with Rated Current ≤ 16 A	EN 61000-3-3: 2013 + A1: 2019 + A2: 2021
Emission Standard for Industrial Environments	EN IEC 61000-6-4: 2019
Mechanical Test	
Vibration Test (Response/Endurance)	IEC 60255-21-1: 1988 Level I
Shock Test (Response/Endurance)	IEC 60255-21-2 Level II
Bump Test (Response Endurance)	IEC 60255-21-2 Level I

Contact us

CET Electric Technology Inc.

Email: support@cet-global.com

Web: www.cet-global.com